



COMPUTER NUMERICAL CONTROL

OSAlcnc S.r.l

CONTENTS

OSAI	01
Version number	02
Loyal Customers	03
Markets	03
Applications	04
Products & services	08
Numerical Controls and accessories	09
CNC Form Factors and Models OSAlcnc Software	09
HMI	12
I/O devices	13
OSAlcnc Software: G-CODES	17
Osai selection table	18
Contact us	20

We Are Osai

Olivetti Sistemi Automazione Industriale

Established in 1957

More than 60 years of CNC experience accumulation and machine tool market cultivation and expansion

Casting "precision, reliability, high performance, personalization"

OSAIcnc has become a leader in the numerical control market, with the mission to innovate constantly



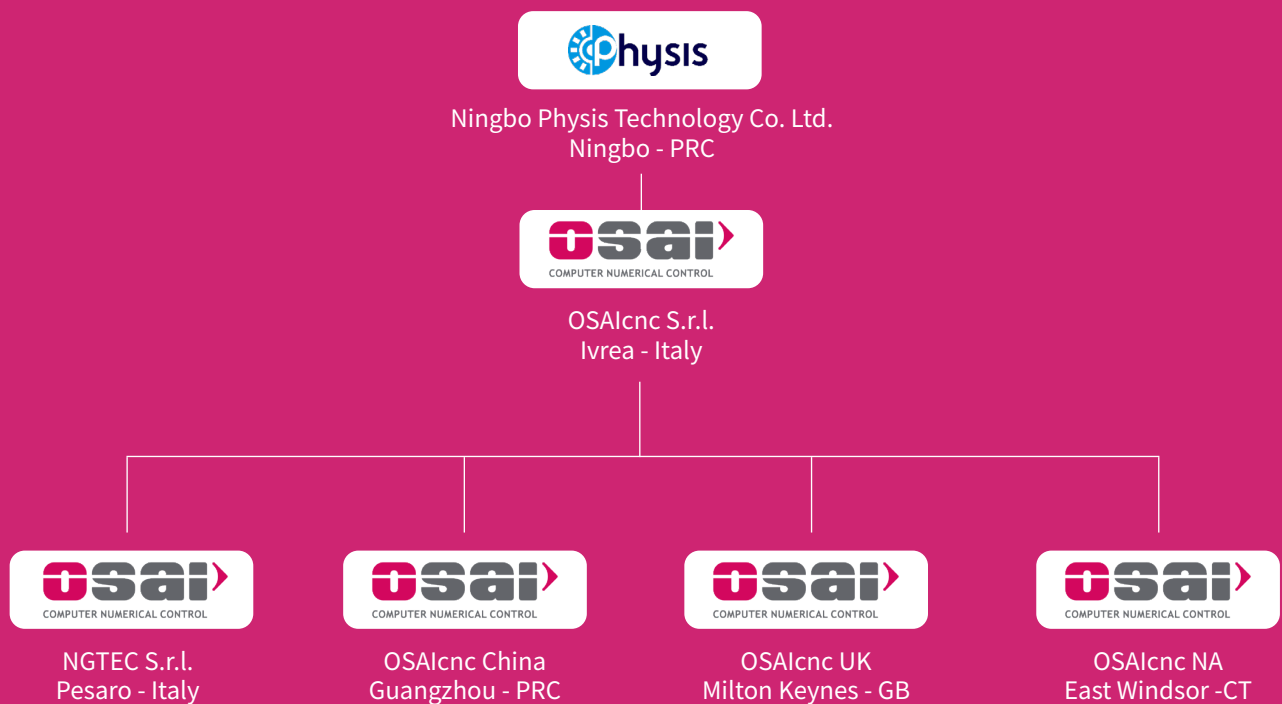
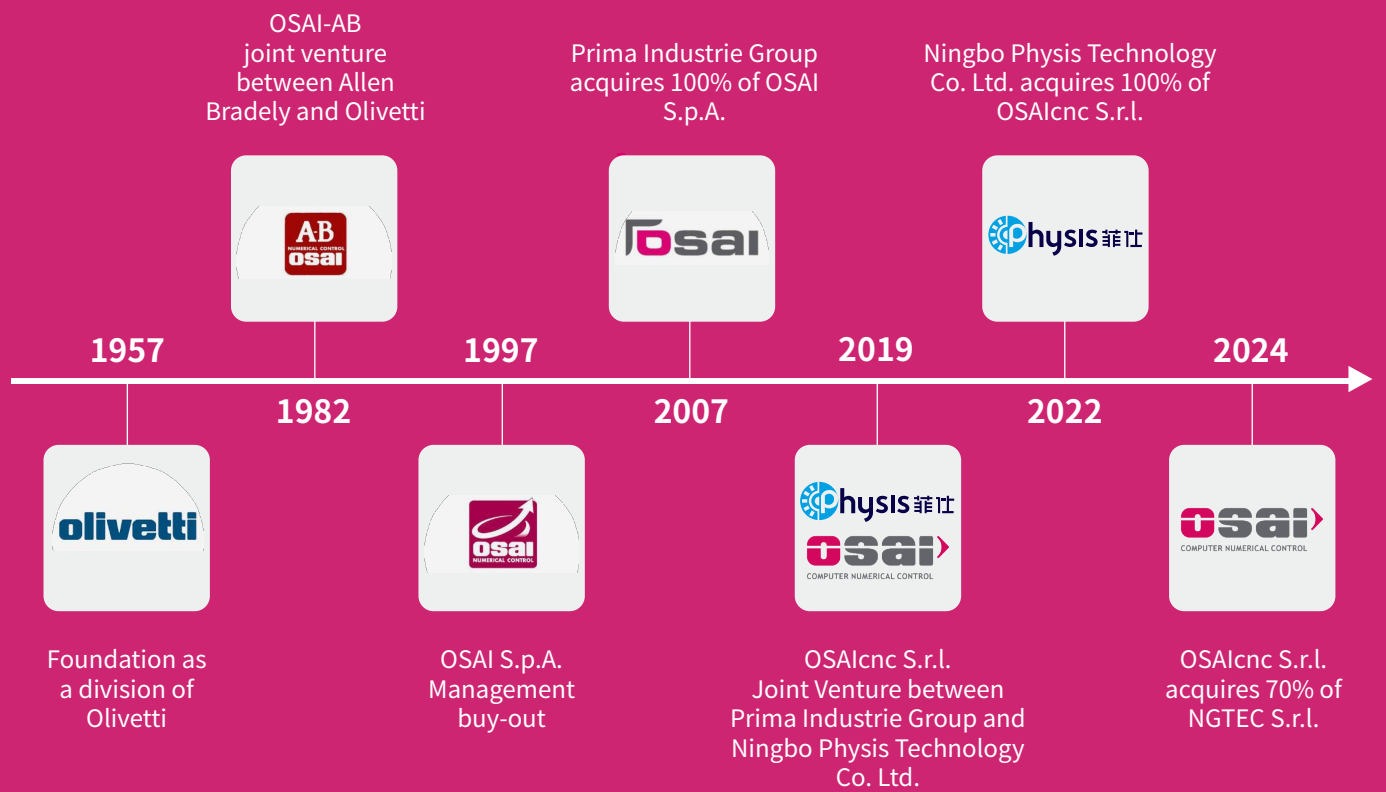

| Loyal Customers



| Markets



Wood and composites



Glass and stone



Metal



Additive & Special application



Laser cutting

| Applications



Wood processing

Drilling machines Pantographs
Milling machines Machining centers
Window and door processing lines
Beam processing machines Lathes
Mortising/tenoning machines

Features:

- Support RTCP tool tip following.
- Support various five-axis structures.
- Supports five-axis automatic calibration.
- Support inclined surface processing.
- Support for 3D tool compensation .
- Support multi-process synchronization.
- Supports dynamic compensation.
- Support joint manipulator.
- Support UI interface customization.

Glass processing

Drilling machines Milling machines Bridge mills Polishers
Cutting tables Waterjet Machining centers

Features:

- Support DXF import.
- Support graphic editing.
- Support current feedback compensation.
- Support sucker control.

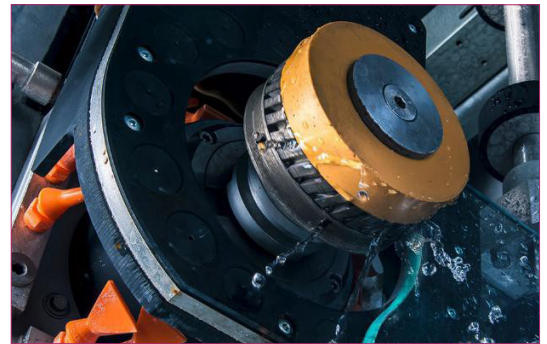

Stone processing

Bridge mills
Polishers Edge
Polishers Waterjet
Machining centers Block cutters

Features:

- Support DXF import.
- Support graphic editing.
- Support five-axis bridge cutting process.
- Support water jet cutting process.
- Support five-axis RTCP algorithm.

Metalsheet processing

Panel benders
Punching machines

Features:

- Support AFE intelligent charge and discharge.
- Support hydraulic pad function.
- Support 3000 groups of parts processing technology.
- Supports the functions of saving, coding and transferring in recipes.
- Support five stamping modes+free programming mode.

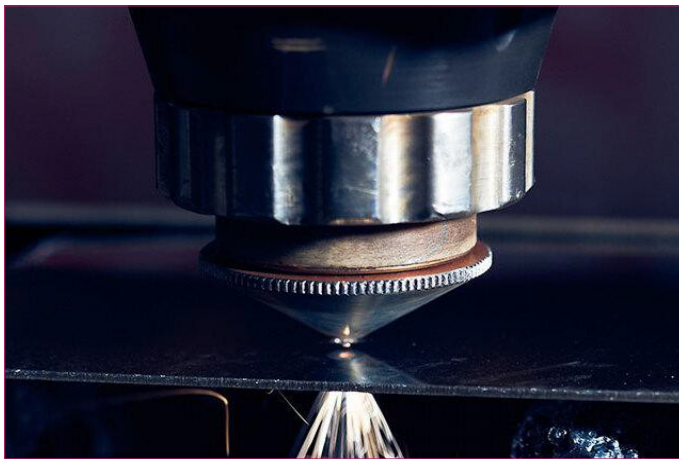
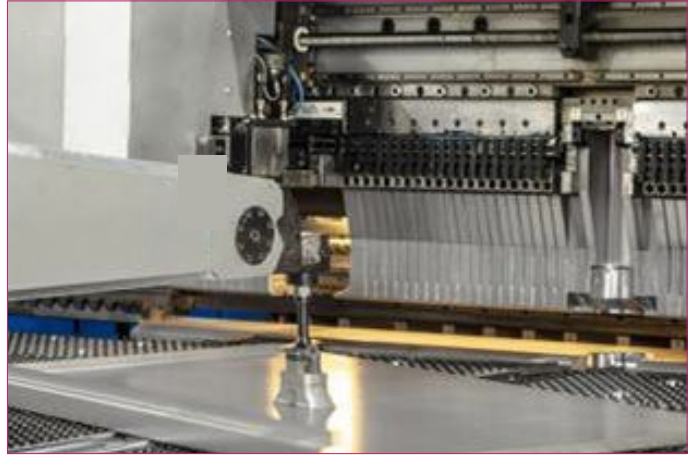

Metal Sheet Cutting

Welding systems Deformation lathes Dental equipment
Metal grinding machines Fiber winding machine Eyewear
machinery
Spray deposition machines Paint spray machines Transfer
machining centers

Features:

- Support PSO control
- Support corner process optimization.
- Support for 3D galvanometer
- Support PLC customized development.
- Support the teaching device function.
- Support PWM laser power control.

Metal milling

Cnc engraving and milling machine
High speed milling machine
Five-axis machining center

Features:

- On-line measurement .
- Support the probe function.
- Support for 3D tool compensation
- Support inclined surface processing.
- Support RTCP tool tip following .
- Support various five-axis structures.
- Supports five-axis automatic calibration.
- Support high-speed and high-precision algorithms.
- Master-slave axis and gantry algorithm .
- Support multi-process synchronization.
- Supports dynamic compensation.
- Space compensation, axis crossing compensation, temperature compensation, etc.



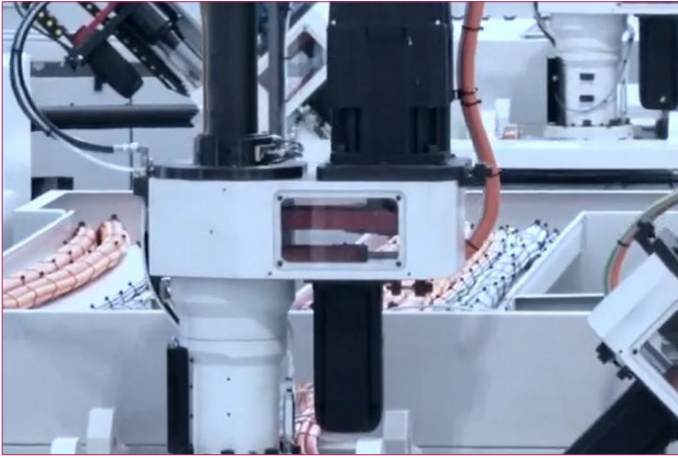

Special machines

laser beam welding machine Turn-milling compound Numerical control grinding machine Fiber winding machine spinning machine

Features:

- Support for secondary development.
- Support joint manipulator Support UI interface customization.
- 5-axis turn-milling RTCP dynamic switching

Additive manufacturing

Large scale 3D printing Hybrid manufacturing 3D printing/Milling 3D printing

Features:

- Temperature compensation
- Precise control of additive temperature
- Accurate control of discharging quantity
- Double five-axis swing head structure
- Double RTCP tip following

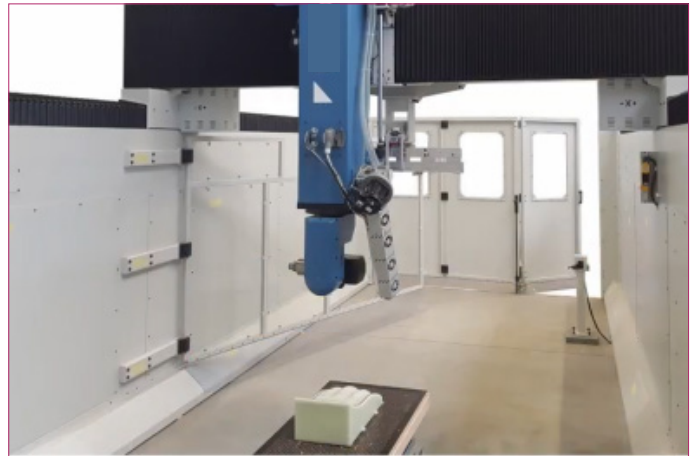

Aluminum and light metal

Profile processing machines for aluminum window frames Machining centers

Features:

- Support RTCP tool tip following
- Support various five-axis structures.
- Supports five-axis automatic calibration.
- Support high-speed and high-precision algorithms

Ultra-precision Machining Solutions

Optical Grinding、 Semiconductor chip manufacturing industry

Multi-wire cutting machine、 Optical milling and grinding machine、 Double-sided grinding machine、 CNC Polishing machine

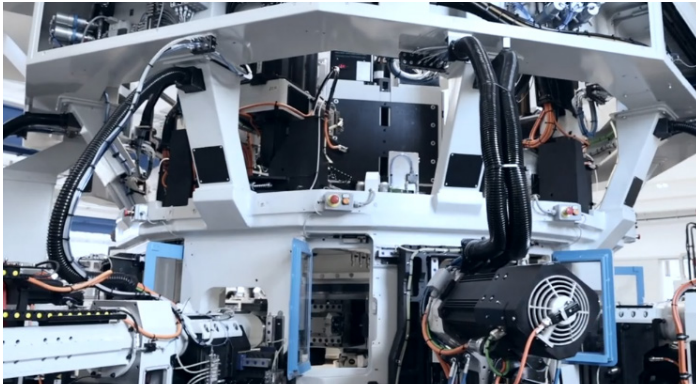

Features:

- Nanometer-level control accuracy
- Tension, Stress control
- Multi-zone pressure control
- Tangential axis control
- Intelligent path optimization
- Online monitoring, dynamic compensation
- Processing formula management
- Multi-axis synchronous control
- 5-axis lathe-milling dynamic switching

Customized production line solution

Provide a full range of hardware, software and robot services, and be able to meet any demand through the most advanced solutions. Can handle any type of machine, including vision system, to realize work automation, save time and optimize resources.

Ngtec Supervisor
data acquisition and monitoring systems system

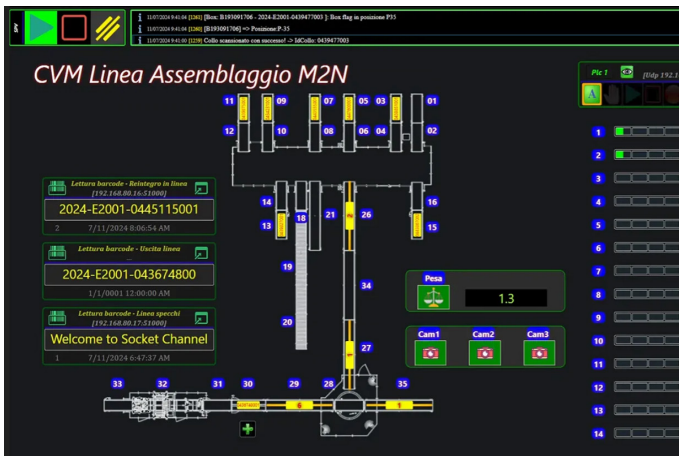

Ngtec Supervisor Data Collection and Monitoring System: Used for data collection, management, and analysis of various equipment and automated production lines within the factory, and connected to the enterprise's management interface to generate fully customized management and analysis reports. Provide strong support for production decision-making and product traceability. Helpful enterprises in transitioning towards comprehensive digital transformation.

Warehouse sorting robot system



The workpieces are transported from the production line to the designated position in a certain order, and the robot controls the special gripper to extract the workpieces and put them into the warehouse. Then the robot puts the workpieces on the designated machine or equipment in the correct order for the subsequent processing machinery. Ngtec manages the whole workflow and tracks the information of all materials in the warehouse.

| Products & services

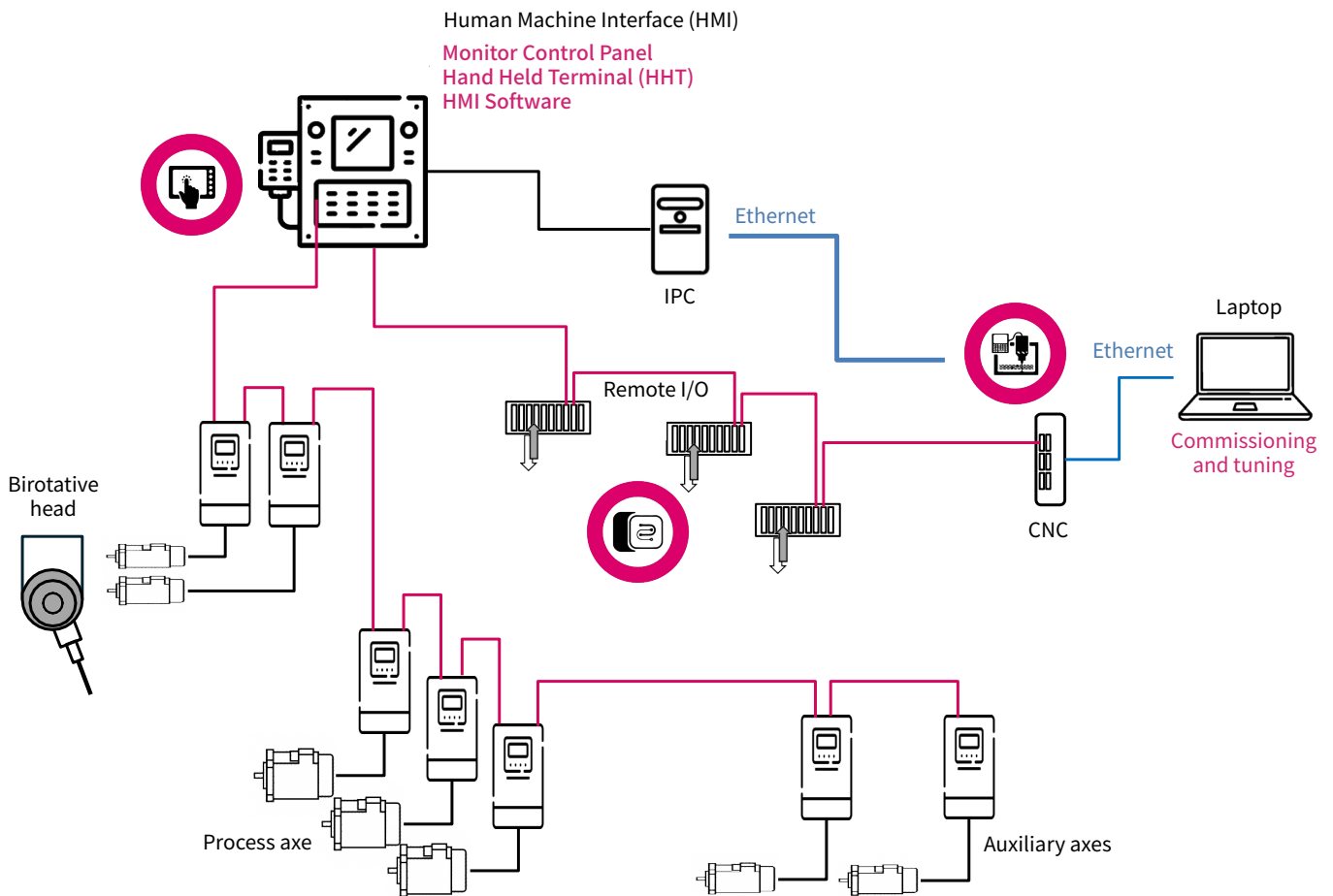
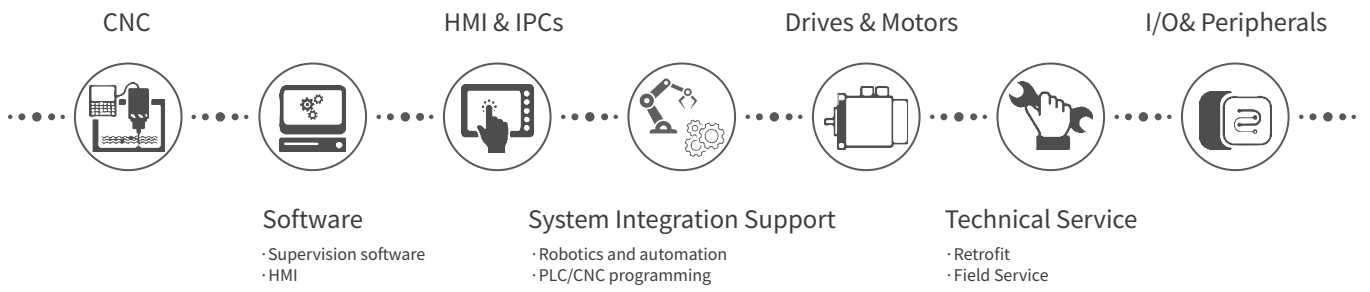

| Numerical Controls and accessories

CNC Form Factors and Models OSAlcnc Software

● OPENcontrol CNC

Booksize



OPENlite OPENsmart/AIRsmart OPENkey/AIRkey OPENprime/AIRprime

AIRgenius

- Wall-mount installation
- Intel architecture
- 0-50 °C
- Fanless

Embedded



OPENNone
High class entry level

- Wall-mount/front-panel installation
- ARM based design
- 0-50 °C
- Fanless

Expandable

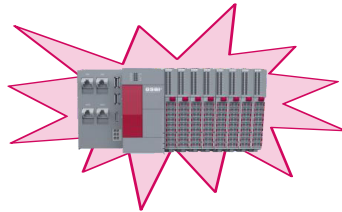

OPENdream
Easy-wiring cabinet solution

- DIN-rail installation
- ARM based design
- Expandable I/O
- 0-50 °C
- Fanless

Soft-CNC



ChronoSOFT

- Soft-CNC solution for MS-Windows IPC

● CNC models: competitive matrix

	ChronoSFT	OPENdream		OPENone	OPENlite	OPENsmart/ AIRsmart	OPENkey/ AIRkey	OPENprime/ AIRprime	AIRgenius
		Linux	Linux	Linux	Windows	Windows Linux	Windows Linux	Windows Linux	Linux
Numerical Control	-	ARM	X86	-	-	-	-	-	-
Interpolator Tick	2ms	2ms	500µs	2ms	2ms	1/2ms	1ms	500µs	500µs
Max interpolated axes	8	4	128 (24 per process)	4	4	8	12 ML or 16 (12 per process)	62 ML or 64 (12 per process)	128(24 per process)
Max axis number	16	8	128	8	8	16 (Max 8 ML)	24 (Max 12 ML)	64 (Max 62 ML)	128
Processes	4	2	24	2	2	2	4	24	24
Retentive memory	Software	Software	Software	Hardware	Hardware	Hardware	Hardware	Hardware	Software
Peripherals									
LAN	User defined	2	2	1	1	1	2	2	2
RS232	User defined	-	-	-	-	1	1	1	1
RS232/422/485	User defined	1	1	1	1	1		1	1
USB	User defined	2x3.0	2x3.0	2x2.0	1X3.0 3x2.0	1X3.0 3x2.0	1X3.0 3x2.0	2x3.0 2x2.0	2x3.0 4x2.0
Video	User defined	HDMI	HDMI	HDMI	HDMI	DVI-I		DVI-D+VGA	-
Fieldbus									
EtherCAT	1	2	2	1	1	1	1	1	1
MECHATROLINK III	-	-	-	-	-	option A	option A	option A	option A
CAN	-	-	-	1	1	option A	option B	option B	option A
MECHATROLINK II/I	-	-	-	-	-	-	option A	option A	-
OSWire	-	-	-	-	-	-	option A	option A	-
I/O									
Fast I/O	-	-	-	1x DI, 1x FDO	-	1x DI, 1x FDO	3 Out, 4 In		1xDI
Analog I/O	-	-	-	1x AO ±10V, 12bit	-	-	1x AI ±10V/4-20mA, 12bit 1x AI ±10V, 12bit 1x AO ±10V, 16bit		-
Optional expansion	-	-	-	24x DI, 16x DO 2x AI ±10V, 12bit 1x ABZ Inc	24xDI,16xDO 2x AI ±10V, 12 bit 1X ABZ Incremental encoder	-	-		-
Encoder In	-	-	-	1x ABZ Inc	1X ABZ Incremental encoder	-	1 x ABZ Inc		-

● OSAlcnc Software concept

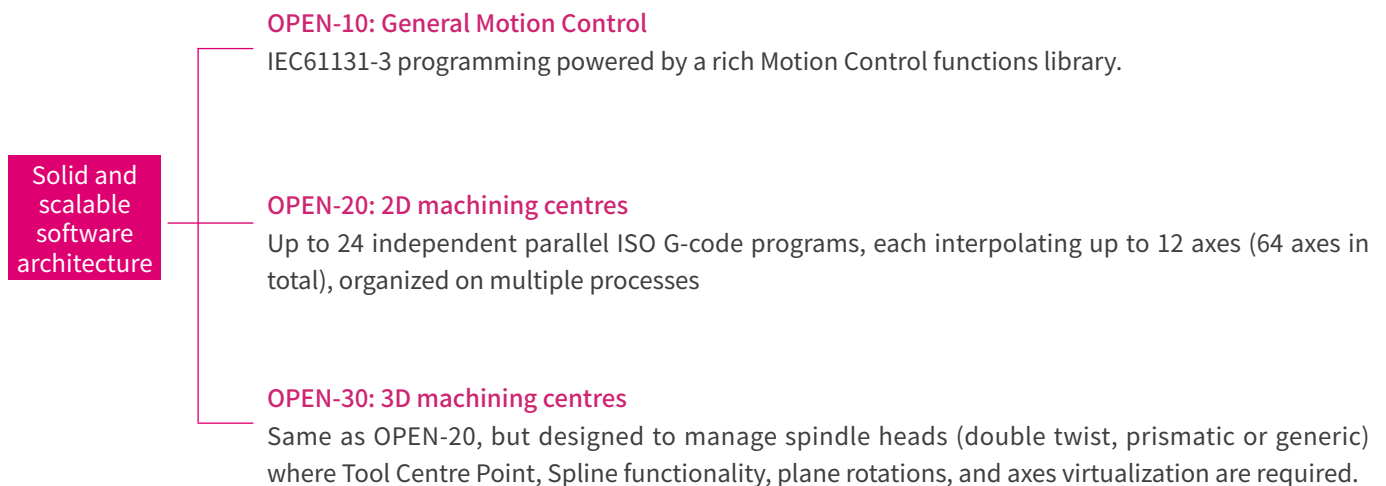

Same software for all CNC models and platform

◆ OSALcnc Software features

AXES Management

- Coordinated, auxiliary, spindle, pseudo axes
- Linear, rotary, rollover
- Dual axes (multi.head machines)
- Master/Slave axes, dynamic follower axes, Tangential axis, Gantry axes

AXES Motion

- Linear, Circular, Circular 3D, Helical, Helical 3D and Spline Interpolation
- Rounding corners
- Multiple reference systems (absolute, temporary, Incremental, origin shift, plane roto translation, scale factor, mirror)
- Tool radius compensation
- Linear, S-shaped, trapezoidal ramp with JRK limitation
- Continuous Mode with look ahead, Motion filters
- Velocity and Acceleration feed forward
- Constant/Variable Pitch, multi-start, Threading (G33)

Tool Center Point

- RTCP for Machine with Double Twist or Prismatic Head
- RTCP for Non-Standard Kinematics
- RTCP with tool direction axis and relevant rotated plane
- Tool wearing compensation
- Predictive dynamics
- Selection by program of active kinematics

Motion Features

- Multi process functionality (up to 24), with Axes Migration and Sharing
- Zero shift
- Multi Block Retrace, Memory Block Search, Active reset

Virtualizations

- Programming on rotated planes
- Polar coordinates, Cylindrical coordinates, non orthogonal axes, SCARA

Compensations

- Backlash
- Single axis bi-directional compensation
- Cross compensation and volumetric compensation

Other

- OPC-UA communication
- Offline CNC-simulator
- visual performance
- PLC function
- Customized production line

● HMI software tools

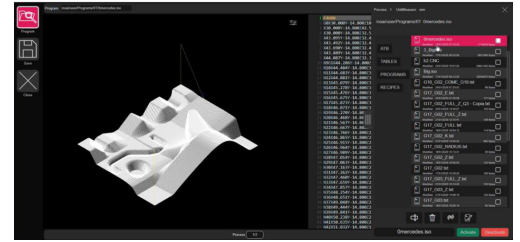
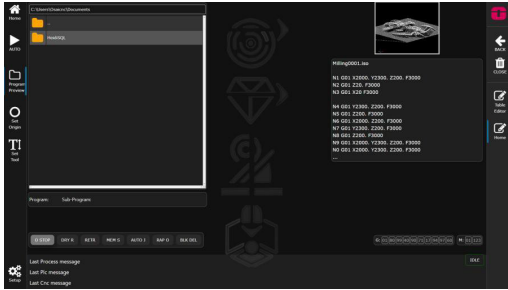

Atmos is a modern and attractive HMI software:

- Web based
- Multiplatform
- Touch Screen oriented
- Adaptive shape (automatically scalable wrt the monitor size)
- Network distribution

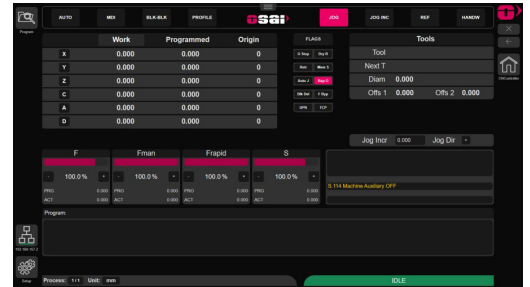
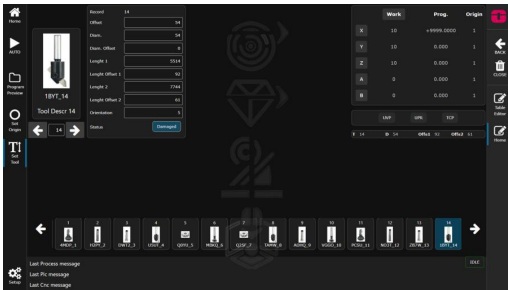

● HMI

Industrial Monitors



Horizontal screen
-4:3 and 16:9 versions
-10' , 15' , 17' , ,

Vertical screen
-4:3 and 16:9 versions
-18' , 21' ,
-Optional mini operation panel

Control panel & keyboard

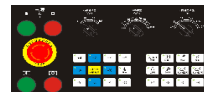

- EtherCAT panel
- 14 key functions
- 2 rotary selection knobs
- 9 custom function interfaces (Ø22.5mm)
- emergency stop and USB interface
- Magnetic keyboard
- IP68 protection
- 100% silicone body
- Machining center panel
- Standard universal full-featured panel
- EtherCAT, I/O
- Mini operation panel
- Suitable for full touch screen interface
- EtherCAT, I/O

HHT



- Wireless handheld terminal
- 4.3" display
- It can run for more than 8 hours on full charge.
- emergency stop and 3-level enabling device
- 2 rotary selection knobs
- Navigation stick
- 5MP camera with LED
- NFC reader
- Magnetic hook
- Support teaching function
- manual pulse generator
- Support wireless wired
- Support function customization

I/O devices

integrated form

OPENbridge 64A and 64P



- EtherCAT slave
- Interface of Analog servodrives
- Interface of P&D servodrives
- 64+64 DI/DO
- 7 ABZ encoder input

OPENbridge 32A



- EtherCAT slave
- Interface of Analog servodrives
- 32+32 DI/DO
- 5 ABZ encoder input

integrated form



Compact I/O (Guide rail installation)

- EtherCAT slave
- 32 DI
- 32 DO
- 2+2 AI, AO
- 2 ABZ enc



OPENxIO Int - standard (Guide rail installation)

- EtherCAT, ProfiNET
- 32 DIO
- 2 configurable SLOTS with a mix of digital and analog I/O

modularize



OPENxIO Pro Flexible, extensible, guide rail installation



- EtherCAT, ProfiNET, EthernetIP, Modbus, slave
- Easily replaceable electronics
- Expansion modules:
- 8, 16, 32 DI
- 8, 16, 32 DO
- 8 OR
- 8 AI current/voltage
- 8 AO voltage Thermal sensor input PWM output
- 2 ABZ encoder HS counter

● I/O devices: I/O Bridge modules



EtherCAT slave modules originally designed for interfacing analog or Pulse&Direction axes to OPENcontrol family CNCs, are often used simply as I/O devices thanks to excellent price/performance ratio and the wide range of I/O. Ideal for new applications as well as old machines retrofit.

	Compact I/O	OPENbridge			
		A-64	P-64	A-32	P-32
Digital Input	32	64	64	32	32
Status LED	Yes	Yes	Yes	Yes	Yes
Protection	Reverse Voltage	-	-	-	-
Digital Output	32	64	64	32	32
Current	0.25/0.5A 8A Max	0.25/0.5A 4A max for 16 O grouping			
Protection	Overload Short Circuit	Overload Short Circuit			
Fail State	Configurable (0/1/f)	-	-	-	-
Analog Input	2	4			
Resolution	12 位	12 bit			
Type	±10V / 0..20mA configurable	±10V			
Bandwidth	1kHz/300Hz	300Hz			
Analog Output	2	7	1	7	1
Resolution	12 位	16 bit			
Type	±10V	±10V			
ABZ enc Input	2	7	7	5	5
latch	Yes	Yes			
Protection	Broken Wire	Broken Wire			

● I/O devices: OPENxIO Int - standard



As a competitive solution in terms of price wrt technology, OPENxIO family provides high-performance and real-time systems supporting the most popular communication busses. Mechanical modularity, scalability and compactness are the key characteristics of the modules.

Type	Description
Coupler	ProfiNet coupler + 32 DIO + 3 conf. Slots
	EtherCAT coupler + 32 DIO + 3 conf. Slots
	ProfiNet coupler + 32 DIO + 2 conf. Slots
	EtherCAT coupler + 32 DIO + 2 conf. Slots

Bus coupler and fixed slot 32 DIO



2 or 3 configurable slots can be equipped with following expansions, or left empty and protected by covers

Type	Description
Digital I/O	16 个 DI, 16 个 DO
	32 DI
	32 DO
	可配置的 32 DIO
Mixed	8 个 DI、8 个 DO、8 个 AI (0-10 V)
	8 个 DI、8 个 DO、8 个 AI (0-20 mA)
	8 个 DI、8 个 DO、4 个 AO (0-10 V)
	8 个 DI、8 个 DO、4 个 AO (0-20 mA)
	8 DI, 8 DO, 4 AI x RTD 4 wire (PT100/200/500/1000)
	8 DI, 8 DO, 4 AI x RTD 2/3 wire (PT100/200/500/1000)
	8 DI, 8 DO, 8 AI x TC 2 wire (K,T,E,J,B,N,R,S)
Analog I/O	8 AI, 8 AO, (0-10V)
	8 AI, 8 AO, (0-20mA)
Special modules	6 D, 4 DO, 2 Channels PosInput (250 kHz)
	8 DI, 8 DO, 4 Channels x RS485

● I/O devices: OPENxIO Pro

As a competitive solution in terms of price wrt technology, OPENxIO family provides high- performance on real-time systems, supporting the most popular fieldbus interfaces.

Mechanical modularity, scalability and compactness are the key characteristics of the modules, together with a sophisticated housing which allows easy installation and servicing.

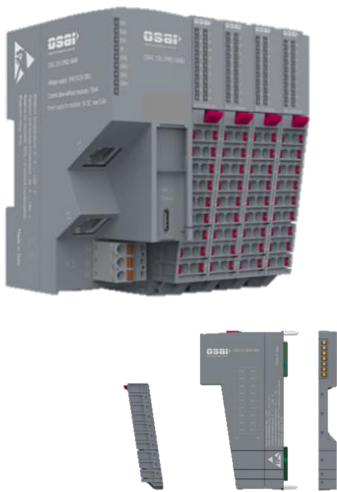
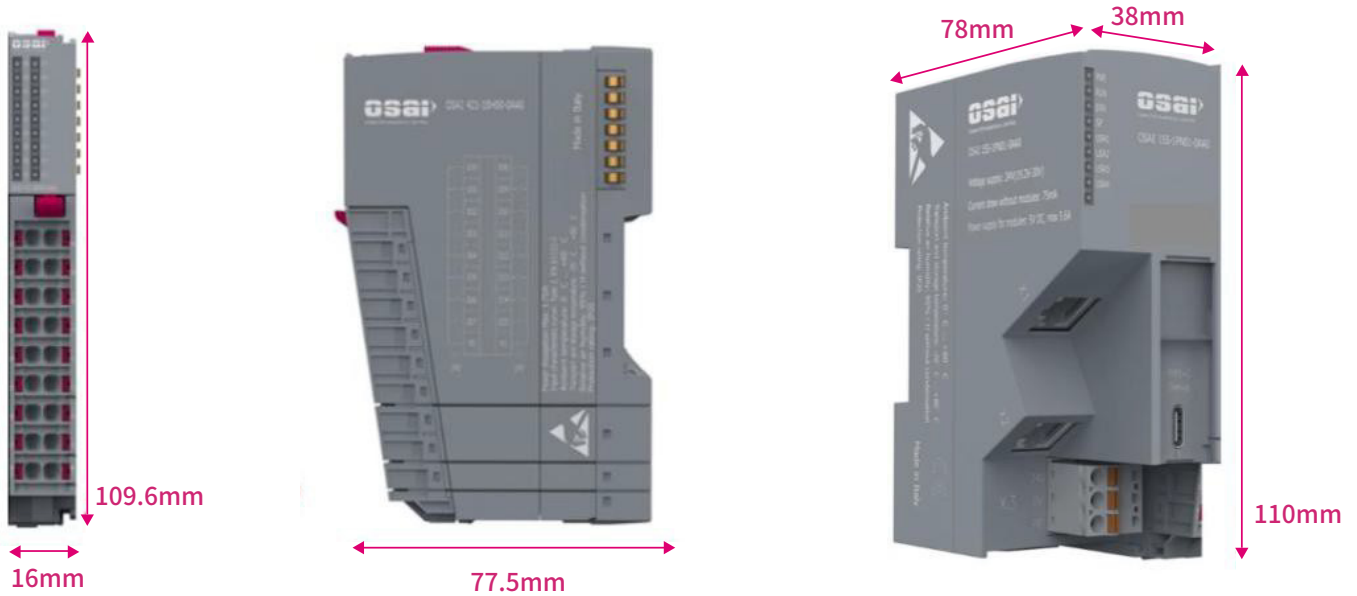

Modules replacable without rewiring or DIN-rail disassembly

Type	Description
Coupler (max 20 expansions)	EtherCAT bus Coupler
	PROFINET bus Coupler
	EtherNET/IP bus Coupler
	Modbus TCP bus Coupler
Digital I/O	8 x Digital Input module - voltage DC24V
	8 x Digital Output module - voltage DC24V, PNP
	16 x Digital Input module - voltage DC24V
	16 x Digital Output module - voltage DC24V, PNP
	32 x Digital Input module - voltage DC24V
Relay	32 x Digital Output module - voltage DC24V, PNP
	8 x Relay Digital Output module - voltage DC24V
Analog I/O	8 x Analog Input module - current 0-20mA, 16bit
	8 x Analog Input module - voltage DC24V, 16bit
	4 x Analog Output module - voltage DC24V, 16bit
	4 x Analog Input module - RTD Resistance Temperature Detector, 24bit
	4 x Analog Input module - TC Thermo Couples, 24bit
Special modules	2 x Encoder High Speed Counter module - 5-24V (config), up to 500 kHz
	Auxiliary Power Supply module - 24V input, 5V/6.4A output
	PWM module
	4 x RS485 module
	4 x RS232 module
	4 x RS422 module



OSAlcnc Software: G-CODES

G CODE	FUNCTION
G00	Rapid axes positioning
G01	Linear interpolation
G02	Circular interpolation CW
G03	Circular interpolation CCW
G04	Dwell at end of step
G05	FeedHold at the end of the movement
G06	FeedHold at the beginning of the movement
G09	Deceleration at end of step
G10	Circular interpolation for three points in space
G12	CCW circular interpolation in space
G13	CW circular interpolation in space
G14	Linear interpolation with dynamic rapid parameters
G16	Defined interpolation plane
G17	Circular interpolation and cutter diameter compensation in the XY plane
G18	Circular interpolation and cutter diameter compensation in the ZX plane
G19	Circular interpolation and cutter diameter compensation in the YZ plane
G26	Operation in continuous sequence with null feed until the block end
G27	Continuous sequence operation with automatic speed reduction on corners
G28	Continuous sequence operation without speed reduction on corners
G29	Point-to-point mode
G31	Identification of the movement that can be stop using ActiveReset
G33	Constant or variable pitch thread
G35	Absolute roto-translation of linear axes three-letter code (it requires option A39)
G36	Roto-translation of a linear axes three-letter code compared to the active origin (it requires option A39)
G37	Coordinates of the theoretical points to define the three-points roto-transaltion
G38	Coordinates of the points measured to define the three-point roto-translation
G39	Activation of the roto-translation defined by three points (it requires option A39)
G40	Disables cutter diameter compensation
G41	Cutter diameter compensation - tool left
G42	Cutter diameter compensation - tool right
G43	Activation of the "Rounding corners" mode
G44	Disables "Rounding corners" mode

G CODE	FUNCTION
G60	Closes spline profile (HSM)
G61	Opens spline profile (HSM) (it requires option A38)
G62	Divides the spline profile in two continuous units
G63	Divides spline profile in two units with connector
G66	Divides spline profile in two units with edge
G67	Divides spline profile in two units with speed rate reduced on the edge.
G70	Programming in inches
G71	Programming in millimetres
G72	Point probing with probe ball radius compensation
G73	Hole probing with probe ball radius compensation
G74	Probing for theoretical deviation from point without probe ball radius compensation
G77	Calculation of the coupling positions given the piece position
G78	Programming referred to the tool tip and motion referred to the machine zero
G79	Programming referred to machine zero
G80	Disables canned cycles
G81	Drilling cycle
G82	Spot-facing cycle
G83	Deep hole drilling cycle
G84	Tapping cycle
G85	Reaming cycle
G86	Boring cycle
G89	Boring cycle with dwell
G90	Absolute programming
G91	Incremental programming
G92	Axis pre-setting without mirror
G93	Inverse time (V/D) feedrate programming
G94	Feedrate programming in ipm or mmpm
G95	Feedrate programming in ipr per revolution or mmpr
G96	Constant surface speed in fpm or mpm
G97	Spindle speed programming in rpm
G98	Axis pre-setting with mirror
G99	Deletes G92

| Osai selection table

Item		ChronoSFT	OPENdream		OPENone	OPENlite	OPENsmart/ AIRsmart	OPENkey/ AIRkey	OPENprime/ AIRprime	AIRgenius	
Product specifications	Number of channels	4	2	24	2	2	2	4	24	24	
	System	Single system (Linux OS)	/	0	0	0	/	▲	▲	▲	▲
		Single system (WEC7)	/	/	/	/	0	▲	▲	▲	▲
		Dual system (WEC7+WES7 (32-bit))	/	/	/	/	/	▲	▲	▲	▲
		Dual system (WEC7+Win10 IoT (64-bit))	/	/	/	/	/	▲	▲	▲	▲
	Interpolation period	2ms	2ms	0.5ms	2ms	2ms	2ms	1ms	0.5ms	0.5ms	
	Maximum number of ganged shafts	8	4	128	4	4	8	16	64	128	
	Maximum number of axes (standard 3 axes)	16	8	128	8	8	16	24	64	128	
	Minimum Control Control Unit	0.001-0.0000001	0.001-0.0000001	0.001-0.0000001	0.001-0.0000001	0.001-0.0000001	0.001-0.0000001	0.001-0.0000001	0.001-0.0000001	0.001-0.0000001	
Maximum number of workpiece coordinate system	300	300	300	300	300	300	300	300	300		
Hardware specifications	Store	User-defined	/	/	1G+4G	4G+120G (expandable)	4G+120G (expandable)	4G+128G (expandable)	4G+128G (expandable)	4G+128G (expandable)	
	I/O Option Module	User-defined	16/16	16/16	16/16	16/16	16/16	16/16	16/16	16/16	
	Analog quantity selection module	User-defined	2in + 2 out	2in + 2 out	2in + 2 out	2in + 2 out	2in + 2 out	2in + 2 out	2in + 2 out	2in + 2 out	
	Fast I/O	User-defined	/	/	1in+1 out		1 out	4 in + 3 out	4 in + 3 out	1 DI	
	Analog input 1	User-defined	/	/	/	/	/	12 Bit ±10V or 4~20mA	12 Bit ±10V or 4~20mA	12 Bit ±10V or 4~20mA	
	Analog input 2	User-defined	/	/	/	/	/	12 Bit ±10V	12 Bit ±10V	12 Bit ±10V	
	Analog output	User-defined	/	/	1	/	/	16 Bit ±10V	16 Bit ±10V	16 Bit ±10V	
	Number of network ports	User-defined	2	2	1	1	1	1	2	2	
	RS232/RS485	User-defined	RS232/ RS485*1	RS232/ RS485*1	RS232/ RS485*1	RS232*1/ RS485*1	RS232*1/ RS485*1	RS232*1/ RS485*1	RS232*1/ RS485*1	RS232*1/ RS485*1	
	USB port	User-defined	USB3.0*2	USB3.0*2	USB2.0*2	USB2.0*3+ USB3.0*1	USB2.0*3+ USB3.0*1	USB2.0*3+ USB3.0*1	USB2.0*2+ USB3.0*2	USB3.0*2+ USB2.0*4	
Display port	User-defined	HDMI	HDMI	HDMI	DVI-I	DVI-I	DVI-I	DVI-I+VGA	DVI-I+VGA		
Servo control	Ethercat	0	0	0	/	0	▲	▲	▲	▲	
	M3 Protocol + Ethercat	/	/	/	/	/	▲	▲	▲	▲	
	M1 Protocol + M2 Protocol + Ethercat	/	/	/	/	/	/	▲	▲	▲	
	CAN+Ethercat	/	/	/	0	/	▲	▲	▲	▲	
	CAN+Profibus+OS-Wire+Ethercat	/	/	/	/	/	/	▲	▲	▲	
Language	Chinese English German French Spanish Italian	0	0	0	0	0	0	0	0	0	
Feed shaft	Interpolation axis, auxiliary axis, virtual axis, line axis, rotation axis	0	0	0	0	0	0	0	0	0	
	Recirculation shaft	0	0	0	0	0	0	0	0	0	
	Diameter shaft	0	0	0	0	0	0	0	0	0	
	Gantry shaft	▲	▲	▲	▲	▲	▲	▲	▲	▲	
	Axis dynamic follow (AXF)	▲	▲	▲	▲	▲	▲	▲	▲	▲	
	Bonding of shafts (UDA, SDA)	▲	▲	▲	▲	▲	▲	▲	▲	▲	
	Master-slave axis (XDA)	▲	▲	▲	▲	▲	▲	▲	▲	▲	
Spindle function	Axis dynamic follow (AXF)	▲	▲	▲	▲	▲	▲	▲	▲	▲	
	Maximum number of spindles	48	48	48	48	48	48	48	48	48	
	Forward/Reverse/Stop/Position	0	0	0	0	0	0	0	0	0	
	Rigid tapping (following tapping, simultaneous tapping, tapping back)	▲	▲	▲	▲	▲	▲	▲	▲	▲	

Item	ChronoSFT	OPENdream	OPENone	OPENlite	OPENsmart/ AIRsmart	OPENkey/ AIRkey	OPENprime/ AIRprime	AIRgenius	
Programming and system operation	Polar coordinates programming	0	0	0	0	0	0	0	
	Cylinder coordinate programming	0	0	0	0	0	0	0	
	Non-orthogonal axis programming	0	0	0	0	0	0	0	
	Metric/Imperial Toggle	0	0	0	0	0	0	0	
	Multifunctional macro programming language	0	0	0	0	0	0	0	
	Fixed machining cycle	0	0	0	0	0	0	0	
	Probe cycle	0	0	0	0	0	0	0	
	Multilevel nested subroutines	0	0	0	0	0	0	0	
	XML macro compiler	▲	▲	▲	▲	▲	▲	▲	
	Sharing of axes	▲	▲	▲	▲	▲	▲	▲	
	Merging of axes	▲	▲	▲	▲	▲	▲	▲	
	Program rollback	0	0	0	0	0	0	0	
	The breakpoint continues	0	0	0	0	0	0	0	
	Handwheel guide	0	0	0	0	0	0	0	
	Area protection	0	0	0	0	0	0	0	
Actual prediction of program loop	0	0	0	0	0	0	0		
High speed and high precision	Linear acceleration, S-shaped acceleration, trapezoidal acceleration	0	0	0	0	0	0	0	
	Jerk Controlled S-Shaped Acceleration	0	0	0	0	0	0	0	
	Point-to-point and continuous interpolation model	0	0	0	0	0	0	0	
	Smoothing filter for programming points (FLT)	0	0	0	0	0	0	0	
	Speed Feed Forward (VFF)	0	0	0	0	0	0	0	
	Corner correction	0	0	0	0	0	0	0	
	TCPPREV	▲	▲	▲	▲	▲	▲	▲	
	SPL3D	▲	▲	▲	▲	▲	▲	▲	
Five-axis function	G60-G67	▲	▲	▲	▲	▲	▲	▲	
	3D circular interpolation	0	0	0	0	0	0	0	
	Shaft Tangential Control	▲	▲	▲	▲	▲	▲	▲	
	Real-Time Tool Center Point (RTCP)	RTCP double swing head or prism structure swing head	/	/	▲	/	▲	▲	▲
		RTCP nonstandard head structure	/	/	▲	/	▲	▲	▲
		RTCP Spline	▲	▲	▲	▲	▲	▲	▲
		Move in the direction of the tool tip	▲	▲	▲	▲	▲	▲	▲
		RTCP rotation plane	▲	▲	▲	▲	▲	▲	▲
		Free switching of different swing head structures	/	/	▲	/	▲	▲	▲
	Five-axis automatic calibration	/	/	0	/	/	0	0	
Compensation function	Bidirectional pitch compensation	0	0	0	0	0	0	0	
	Backlash compensation	0	0	0	0	0	0	0	
	Temperature compensation	▲	▲	▲	▲	▲	▲	▲	
	Inter-axis cross compensation	▲	▲	▲	▲	▲	▲	▲	
	Space compensation	▲	▲	▲	▲	▲	▲	▲	
HMI	Full touch operation panel	▲	▲	▲	▲	▲	▲	▲	
	Operation panel 1	▲	▲	▲	▲	▲	▲	▲	
	Operation panel 2	▲	▲	▲	▲	▲	▲	▲	

Indicate: (standard,▲ optional,/Not supported)

| Contact Us

菲仕总部 PHYSIS HEADQUARTER

宁波菲仕技术股份有限公司

Ningbo Physis Technology Co., Ltd.

销售热线 /Tel: +0086- (0) 0574-26922588 / +0086- (0) 0574-26922600

邮箱 /E-mail: Sales@physis.com.cn

意大利欧赛 /OSAIcnc S.r.l

销售热线 /Tel: +39 0125 1906267

邮箱 /E-mail: sales@osaicnc.com

官网 /Web: www.osaicnc.com

英国欧赛 /OSAI-UK LTD

销售热线 /Tel: +44 (0) 1908 642687

+44 (0) 1908 642688

邮箱 /E-mail: uk.sales@osaicnc.com

广州欧赛 /OSAI CHINA Co.Ltd

销售热线 /Tel: +86 020-87518211

+86 020-38491180

邮箱 /E-mail: cn.sales@osaicnc.com

美国欧赛 /OSAI USA, LLC

销售热线 /Tel: +1 413 598 5200

+1 413 598 5201

邮箱 /E-mail: us.sales@osaicnc.com

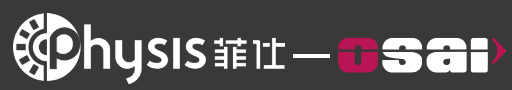

Scan to learn more

Version number: PHCC2604-V01