

TK Series DD Servo Motors

TK系列直驱力矩电机

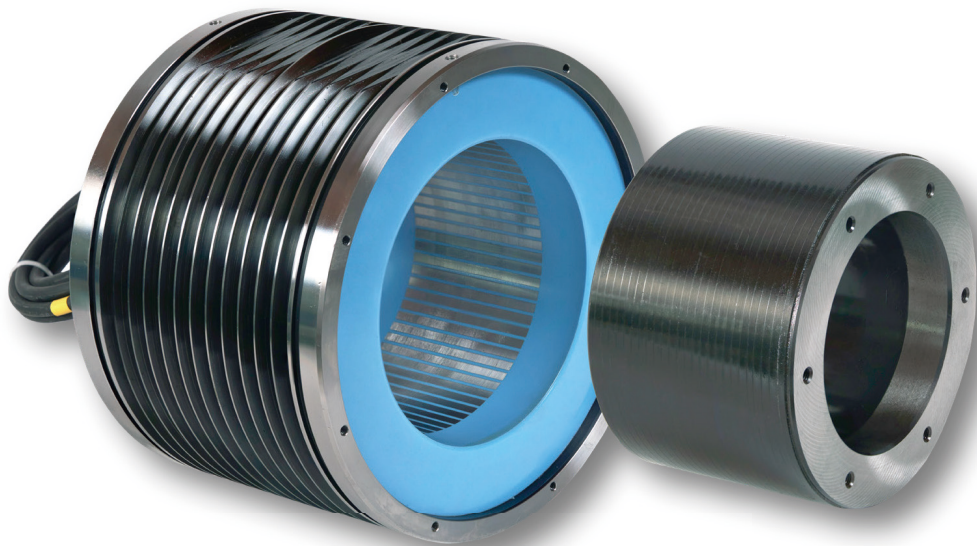



Company Profile 企业简介

宁波菲仕技术股份有限公司（简称：菲仕技术）成立于2001年，由民营控股、先进制造产业投资基金和宁波通商集团等战略投资人参股，公司致力于以“高效节能、精准控制”电驱动技术为核心的创新及产业化，为运动控制和能量转换领域提供系统产品和综合解决方案，经过多年品牌沉淀，菲仕已成为一家集研发、生产、销售为一体，拥有国内外多家控股子公司的集团化创新型高科技企业。

Ningbo Physis Technology Co., Ltd. (hereinafter referred to as Physis) was founded in 2001. Physis always devotes to innovation and industrialization of electrical drive technology, provides servo products and solutions for the field of motion control & energy conversion. After years of brand development and accumulation, Physis becomes a collectivized & innovative high-tech enterprise, which collects together R&D, manufacturing and sales, and has a numbers of domestic and overseas subsidiaries.

Global presence 全球布局

立足全国 放眼全球

总部“永动谷”落户中国宁波北仑，在国内产业链完善的宁波、株洲、天津、赣州建立大型生产基地。建立国内外分子公司17家，合作伙伴百余家，形成覆盖全国、面向全球市场的营销服务网络，逐步落地国际化战略。

Physis has established large-scale production bases in Ningbo, Zhuzhou, Tianjin, and Guangzhou, which have a complete domestic industrial chain.

It has established 17 domestic and foreign subsidiaries and more than 100 partners, formed a marketing service network covering the whole country and facing the global market, and gradually implemented the internationalization strategy.

CONTENTS 目录

产品介绍 Products Introduction	01
应用领域 Application	02
TK 系列伺服电机代码 Servo Motor Code	02
TK085	03
TK106	04
TK110	05
TK142	07
TK164	08
TK172	10
TK188	11
TK220	12
TK230	14
TK240	15
TK270	16
TK310	17
TK340	18
TK360	19
TK370	20
TK440	21
TK450	22
TK540	23
TK570	24
TK615	25
TK795	26
TK1000	28
TK1280	29
TK1340	30
TK1700	31
联系我们 Contact Information	32

Products Introduction

产品介绍

功率范围：3.2~800KW
扭矩范围：3~120000Nm
转速范围：0~30000rpm
直径范围：85~2000mm
冷却方式：自然冷、风冷、液冷
适用范围：工业自动化通用伺服

Power Range:3.2~800 KW
Torque Range:3~120000 Nm
Speed Range:0~30000 rpm
Diameter range:85~2000mm
Cooling:natural convection, fan cooled and liquid cooling

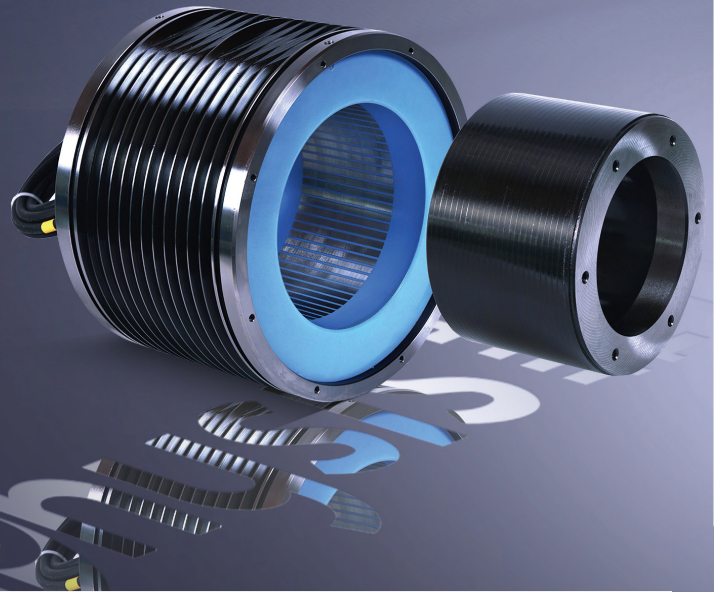

高功率密度

采用高性能的永磁材料，高牌号硅钢片，先进的电磁方案，实现高转速和高转矩能力以及弱磁控制能力，恒功率范围可达 10: 1。

高效率

提供符合 GB30549，最高一级，和 IEC60034，最高 IE5 的解决方案。

结构简单

无框架结构，适于集成到设备内部，适配性强，安装方便，容易维护。

耐用

定子采用真空环氧灌封工艺和超行业水平的绝缘材料，提高电机防护等级和散热性能，使电机更持久耐用。

灵活定制

整机和无框架可选，为不同应用场景提供基于平台的全方位非标定制方案，目前最大直径可达 45m。

High power density

The use of high-performance permanent magnet materials, high grade silicon steel sheet, advanced electromagnetic solutions, to achieve high speed and high torque and weak magnetic control ability, constant power range up to 10:1

High efficiency

Provides solutions conforming to GB30549, highest level, and IEC60034, highest IE5.

Simple structure

No frame structure, suitable for integration into the equipment, strong adaptability, easy installation, easy maintenance

Durable

The stator adopts vacuum epoxy filling process and super industry level insulation material to improve the protection level and heat dissipation performance of the motor, so that the motor is more durable.

Flexible customization

Complete machine and no frame optional, provides a full range of platform based non-standard customization solutions for different application scenarios, the maximum diameter up to 45m.

Application 应用领域



机床 Machine tool

油气钻采 Oil and gas drilling

天文望远镜 Astronomical telescope

缆车 Cable car

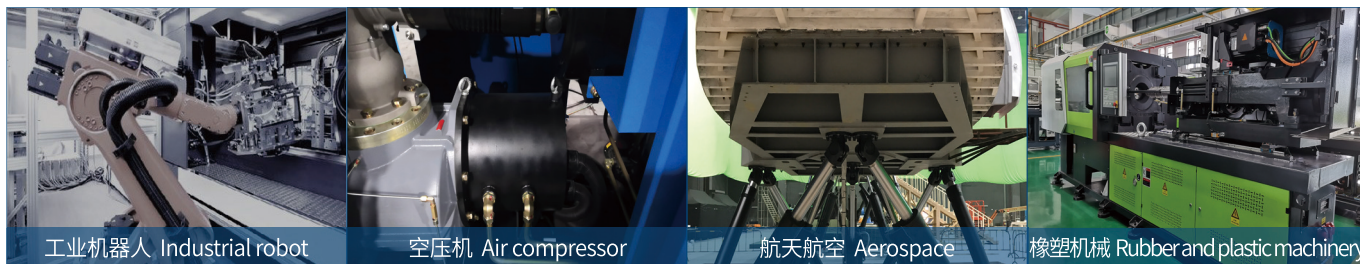

工业机器人 Industrial robot

空压机 Air compressor

航天航空 Aerospace

橡塑机械 Rubber and plastic machinery

Servo Motor Code TK 系列伺服电机代码

TK 85 - 050 - 025 C

电机类型
Series Identify

嵌线定子外径
Outer diameter
of stator

85mm

定子长度
Stator length

50mm

力矩常数
Torque
constant

2.5Nm/Arms

冷却方式
Cooling

C = 水冷却
A = 自然冷却
Y = 油冷

C = water cooling
A = natural convection
Y = oil cooling

注：样本上仅展示了部分机型，其他性能需求或定制需求请联系我们。

Note: Only some models are shown on the sample. For other performance or customization requirements, please contact us.

TK085

性能参数

电机型号 Motor Code	额定转速 Rated Speed	最大速度 Max Speed	额定电流 Rated Current	额定转矩 Rated Torque	额定功率 Rated Power	转矩常数 Torque Constant	最大电流 Max Current	最大转矩 Max Torque
	w_n [rpm]	w_{max} [rpm]	I_n [A]	T_n [Nm]	P_n [kW]	K_t [Nm/A]	I_{max} [A]	T_{max} [Nm]
TK085-50-025C	1500	3500	3.4	7	1.1	2.28	13	24
TK085-50-005C	10000	15000	12	6	6.3	0.57	53	24
TK085-100-008C	6500	10000	14.6	10.6	7.2	0.82	59	24
TK085-100-006C	6000	35000	25.2	10	6.3	0.46	132	48
TK085-100-003C	10000	30000	27	8	8.4	0.34	176	48

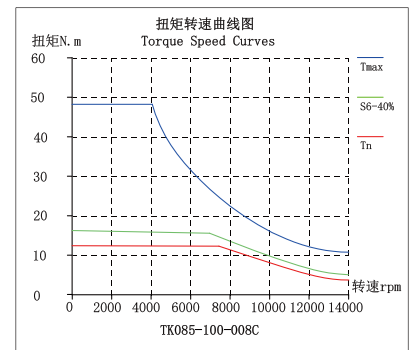
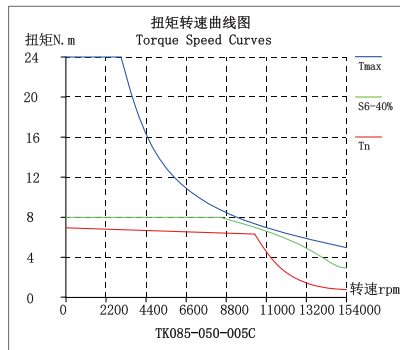
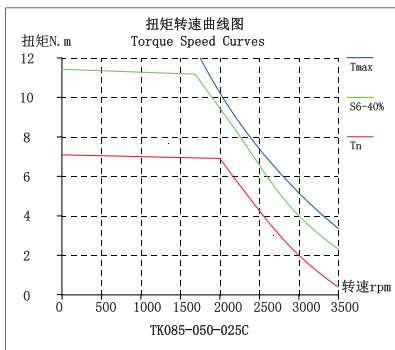

尺寸参数

电机型号 Motor Code	DS1	DS2	DS3	DS4	DR1	DR2	DR3	Stk	Tax1	Tax	LR	L
TK085-50-025C	90.5	61	79	58.2	57.2	36	37	53	21.5	17.5	62	4.5
TK085-50-005C	90.5	60	79	58.2	57.2	35	36	53	21.5	17.5	64	5.5
TK085-100-008C	90.5	79	61	58.2	57.2	30	31	100	24	19	114	7
TK085-100-006C	90.5	61	82	58.2	57.2	37	38	103	22.5	17.5	112	4.5
TK085-100-003C	90.5	61	82	58.2	57.2	37	38	103	22.5	18	112	4.5

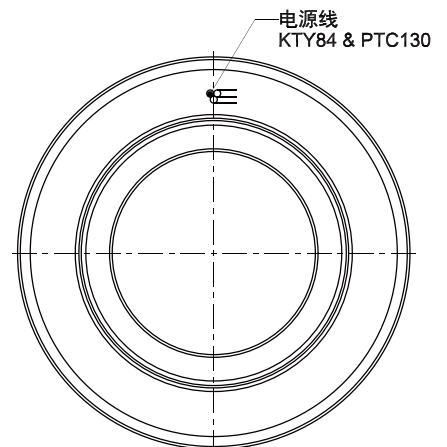
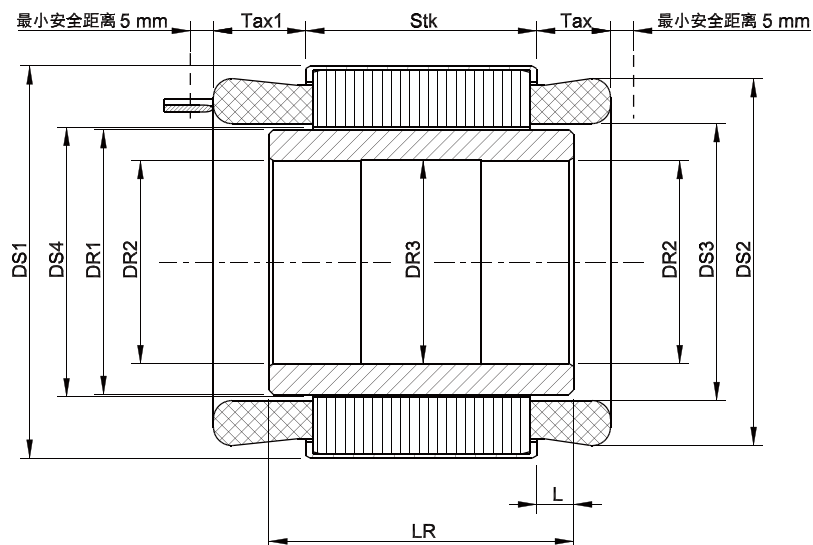

TK106

性能参数

电机型号 Motor Code	额定转速 Rated Speed	最大速度 Max Speed	额定电流 Rated Current	额定转矩 Rated Torque	额定功率 Rated Power	转矩常数 Torque Constant	最大电流 Max Current	最大转矩 Max Torque
	w_n [rpm]	w_{max} [rpm]	I_n [A]	T_n [Nm]	P_n [kW]	K_t [Nm/A]	I_{max} [A]	T_{max} [Nm]
TK106-100-025C	2000	2600	12.6	30	6.3	2.55	43	88
TK106-100-035A	1600	1800	3	10	1.7	3.55	3.2	88
TK106-155-06C	600	1100	8.7	48.7	3.1	6.23	27	124

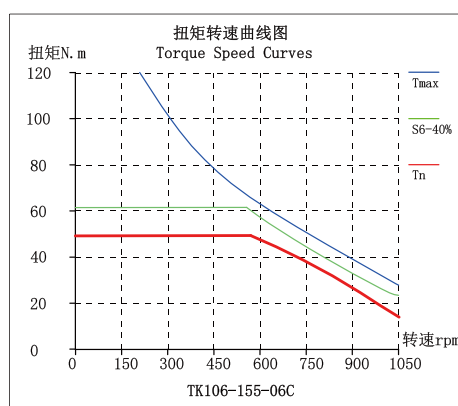
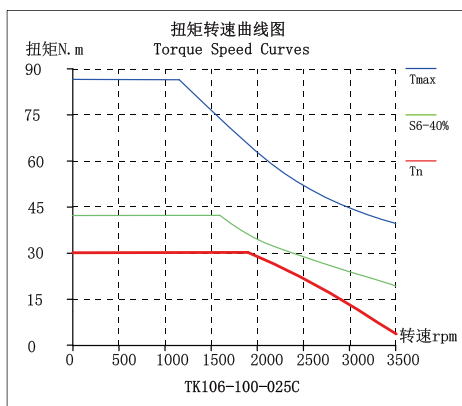

尺寸参数

电机型号 Motor Code	DS1	DS2	DS3	DS4	DR1	DR2	DR3	Stk	Tax1	Tax	LR	L
TK106-100-025C	106	100	81	78.8	77.6	45	45.5	103	21	16	120	8.5
TK106-100-035A	108	100	81	78.8	77.6	45	45.5	100	22.5	17.5	120	10
TK106-155-06C	106	100	81	78.8	77.6	45	45.5	158	21	16	175	8.5

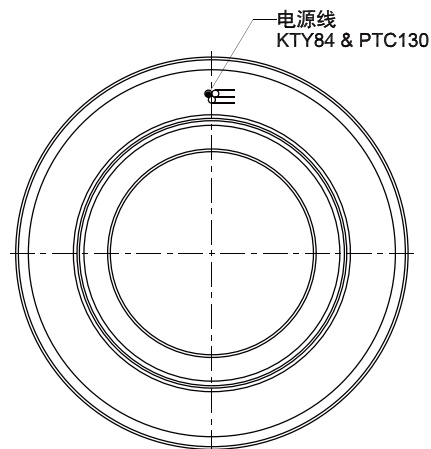
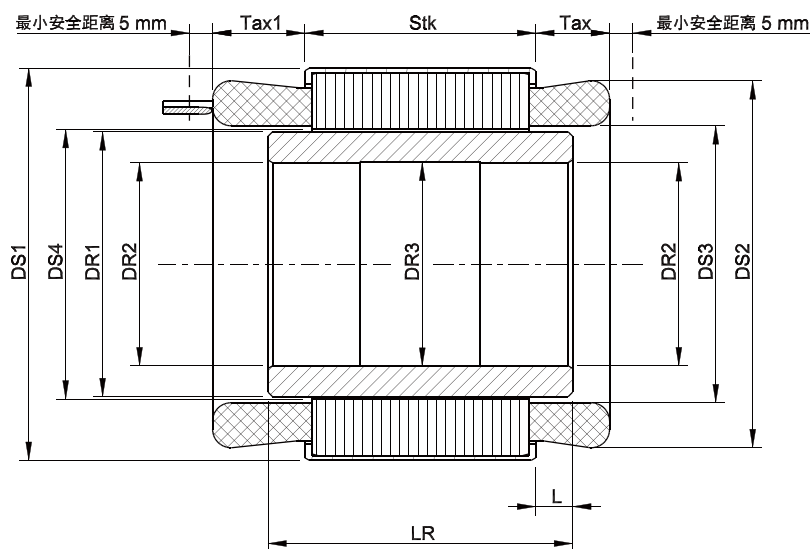

TK110

性能参数

电机型号 Motor Code	额定转速 Rated Speed	最大速度 Max Speed	额定电流 Rated Current	额定转矩 Rated Torque	额定功率 Rated Power	转矩常数 Torque Constant	最大电流 Max Current	最大转矩 Max Torque
	ω_n [rpm]	ω_{max} [rpm]	I_n [A]	T_n [Nm]	P_n [kW]	K_t [Nm/A]	I_{max} [A]	T_{max} [Nm]
TK110-060-009C	4500	10000	19.7	15	7.1	0.86	60	40
TK110-060-012C	3000	6500	12	13.1	4.1	1.21	44	40
TK110-080-016C	3000	6500	12.5	18.5	5.8	1.61	44	53
TK110-090-016C	3000	10000	14	20	6.3	1.59	42	53
TK110-110-02C	2000	2900	12.5	25	5.2	2.26	36	73
TK110-110-06C	500	940	4.3	25	1.3	6.68	12	65
TK110-120-004C	11000	25000	43	16	18.4	0.45	221	80
TK110-120-009C	4500	18000	34.3	24.7	11.6	0.9	93	46
TK110-150-012C	4000	8000	38.4	36.6	15.3	1.07	127	100
TK110-180-009C	5500	15000	51.5	36	20.7	0.9	140	69

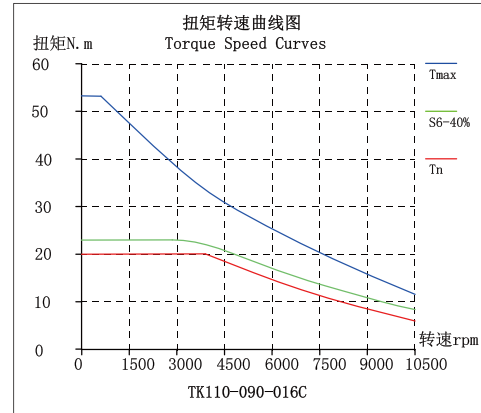
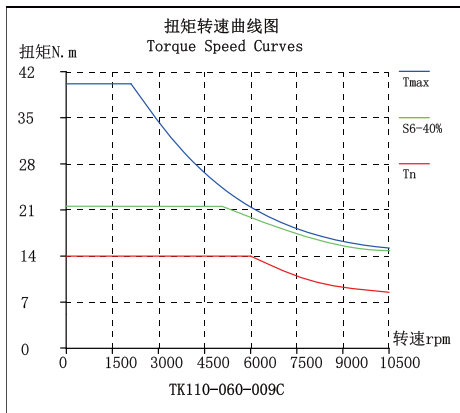

尺寸参数

电机型号 Motor Code	DS1	DS2	DS3	DS4	DR1	DR2	DR3	Stk	Tax1	Tax	LR	L
TK110-060-009C	111	100	71	68.5	66.5	50	50.5	63	26.5	18.5	73	5
TK110-060-012C	111	100	71	68.5	66.5	45	46	63	23.5	18.5	76	6.5
TK110-080-016C	111	100	71	68.5	66.5	45	46	83	23.5	18.5	96	6.5
TK110-090-016C	111	100	71	68.5	66.5	51	51.5	93	27.5	18.5	119	13
TK110-110-02C	111	100	71	68.5	66.5	43	44	113	26.5	18.5	126	6.5
TK110-110-06C	111	100	71	68.5	66.5	43	44	113	26.5	18.5	126	6.5
TK110-120-004C	111	100	71	68.5	66.5	45.8	41.5	123	26.5	18.5	140	8.5
TK110-120-009C	111	100	71	68.5	66.5	45.8	41.5	123	26.5	18.5	140	8.5
TK110-150-012C	111	100	71	68.5	66.5	42	43	153	26.5	18.5	166	6.5
TK110-180-009C	111	100	71	68.5	66.5	42	43	183	26.5	18.5	200	8.5

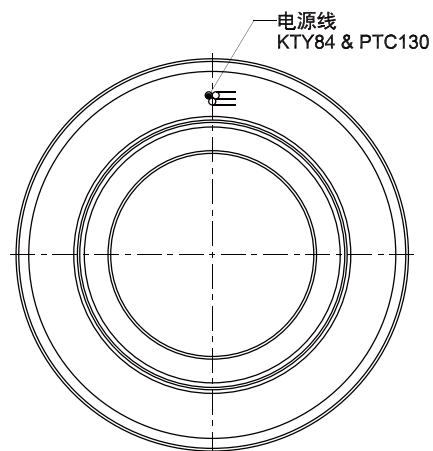
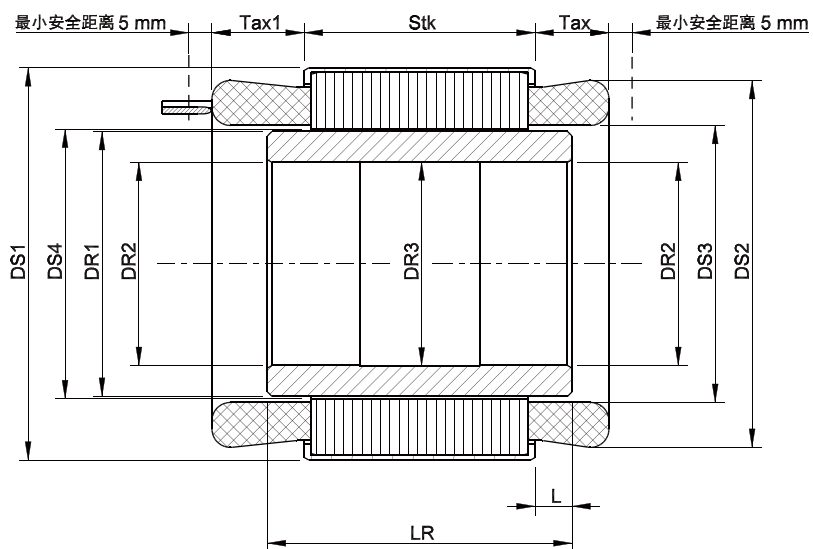

TK142

性能参数

电机型号 Motor Code	额定转速 Rated Speed	最大速度 Max Speed	额定电流 Rated Current	额定转矩 Rated Torque	额定功率 Rated Power	转矩常数 Torque Constant	最大电流 Max Current	最大转矩 Max Torque
	w_n [rpm]	w_{max} [rpm]	I_n [A]	T_n [Nm]	P_n [kW]	K_t [Nm/A]	I_{max} [A]	T_{max} [Nm]
TK142-060-013C	3500	10000	25	28	10.3	1.28	76	74
TK142-060-022C	1500	8000	14.8	28.5	4.5	2.2	44	74
TK142-100-073C	550	900	10.5	68.5	3.9	7.33	21	128
TK142-120-052A	500	1130	5.3	25.4	1.3	5.16	15	72

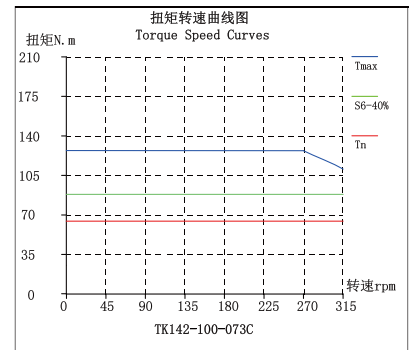
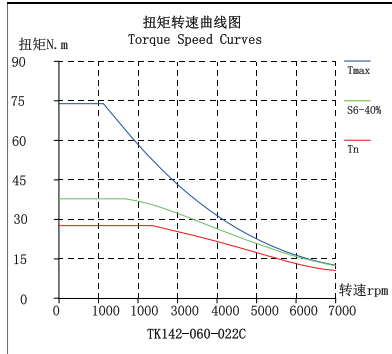
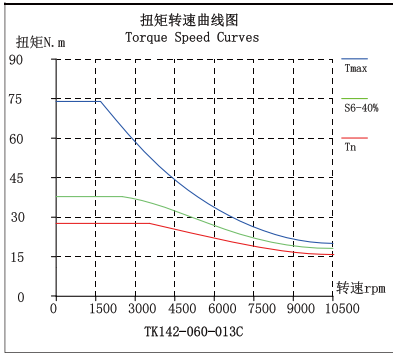

尺寸参数

电机型号 Motor Code	DS1	DS2	DS3	DS4	DR1	DR2	DR3	Stk	Tax1	Tax	LR	L
TK142-060-013C	143.2	133	98	95	94	76	76.5	63	21.5	16.5	85	11
TK142-060-022C	143.2	133	98	95	94	70	71	63	21.5	16.5	78	7.5
TK142-100-073C	143.2	133	98	95	94	70	71	103	21.5	16.5	135	16
TK142-120-052A	140	130	101	95	94	47	45	120	21	18	126	3

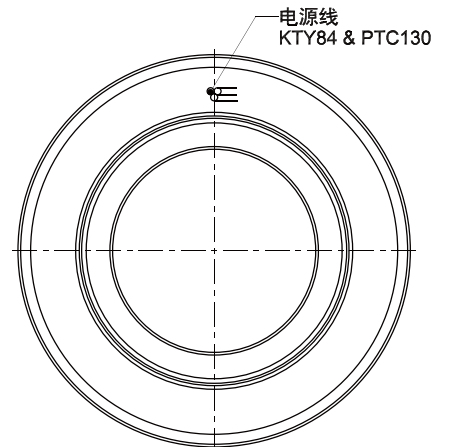
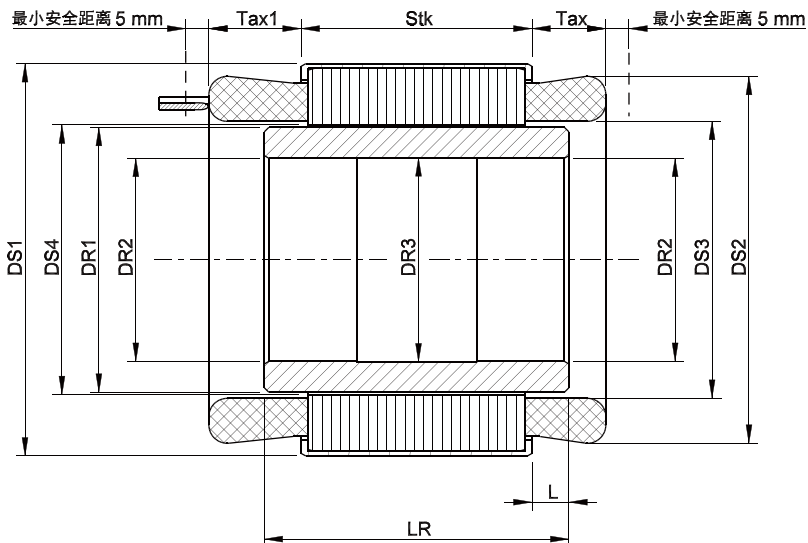

TK164

性能参数

电机型号 Motor Code	额定转速 Rated Speed	最大速度 Max Speed	额定电流 Rated Current	额定转矩 Rated Torque	额定功率 Rated Power	转矩常数 Torque Constant	最大电流 Max Current	最大转矩 Max Torque
	ω_n [rpm]	ω_{max} [rpm]	I_n [A]	T_n [Nm]	P_n [kW]	K_t [Nm/A]	I_{max} [A]	T_{max} [Nm]
TK164-030-013C	1500	7000	12.5	14.9	2.3	1.3	54	56
TK164-045-016C	3700	6000	18.2	22	8.5	1.59	65	84
TK164-045-024C	1000	3000	18	38.8	4.1	2.44	43	84
TK164-055-10C	300	636	5	40	1.3	9.81	12	86
TK164-060-016C	2000	6000	27.4	41	8.6	1.62	87	112
TK164-070-017C	3600	6000	24.9	39	14.7	1.65	93	130
TK164-080-035C	1300	2000	18.7	60	8.2	3.64	51	150
TK164-090-049C	500	800	19	83	4.3	4.88	43	168
TK164-100-028C	1700	5000	29.1	74	13.2	2.83	80	177
TK164-110-02C	2600	5000	46	85.3	23.2	2.05	110	208
TK164-120-14A	350	500	3	39	1.4	14.06	18	198
TK164-120-047A	1250	1500	8.3	35.6	4.7	4.69	57	211
TK164-130-073A	780	1200	5.8	40	3.3	7.28	40	241
TK164-140-025C	1700	5000	40	90	16	2.47	133	262
TK164-160-13A	400	500	5.3	66	2.8	13.44	25	266
TK164-180-045C	1000	5000	43.3	171	17.9	4.48	67	337

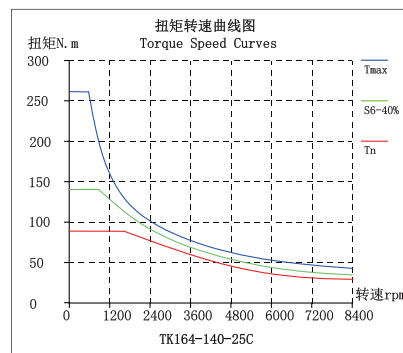
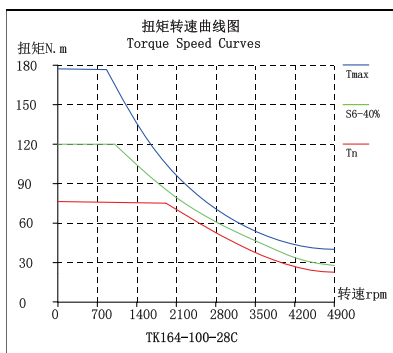
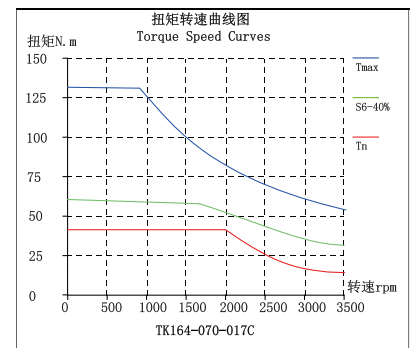
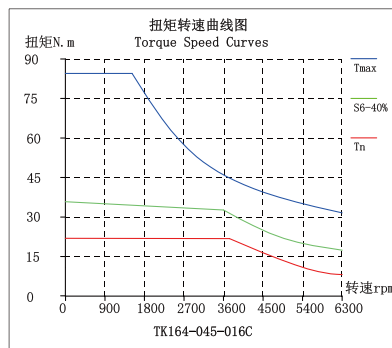
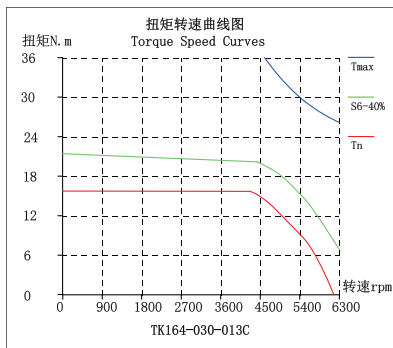

尺寸参数

电机型号 Motor Code	DS1	DS2	DS3	DS4	DR1	DR2	DR3	Stk	Tax1	Tax	LR	L
TK164-030-013C	165	153	119.4	115	113.8	80	82	34	23	18	48	7
TK164-045-016C	165	153	119.4	115	113.8	86	87	49	23	18	59	5
TK164-045-024C	165	153	119.4	115	113.8	85	86	49	19	17	63	7
TK164-055-10C	165	153	119.4	115	113.8	86	87	59	24	16	69	5
TK164-060-016C	165	153	119.4	115	113.8	81	80	64	23	18	74	5
TK164-070-017C	165	153	119.4	115	113.8	86	87	74	23	18	84	5
TK164-080-035C	165	153	119.4	115	113.6	75	77	84	23	20	124	20
TK164-090-049C	165	153	119.4	115	113.8	85	86	94	19	17	104	5
TK164-100-028C	165	153	119.4	115	113.8	90	90.2	104	23	18	118	7
TK164-110-02C	165	153	117	115	113.8	90	90.2	114	20	16	127	6.5
TK164-120-14A	162	153	118	115	113.8	80	81	120	23	20	135	7.5
TK164-120-047A	162	153	118	115	113.8	80	81	120	23	20	135	7.5
TK164-130-073A	162	153	118	115	113.8	85	86	130	23	20	144	7
TK164-140-025C	165	153	119.4	115	113.8	86	87	144	23	18	154	5
TK164-160-13A	165	153	119.4	115	113.8	86	87	160	27	22	174	7
TK164-180-045C	165	153	119.4	115	113.8	86	87	184	25	20	194	5

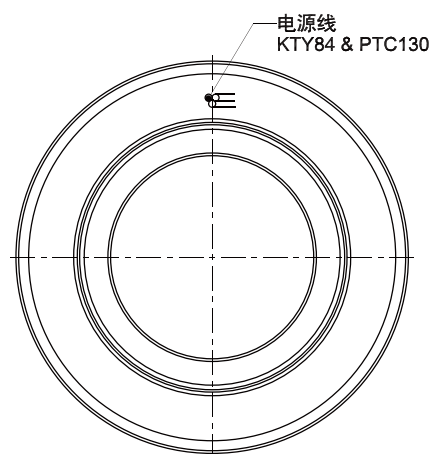
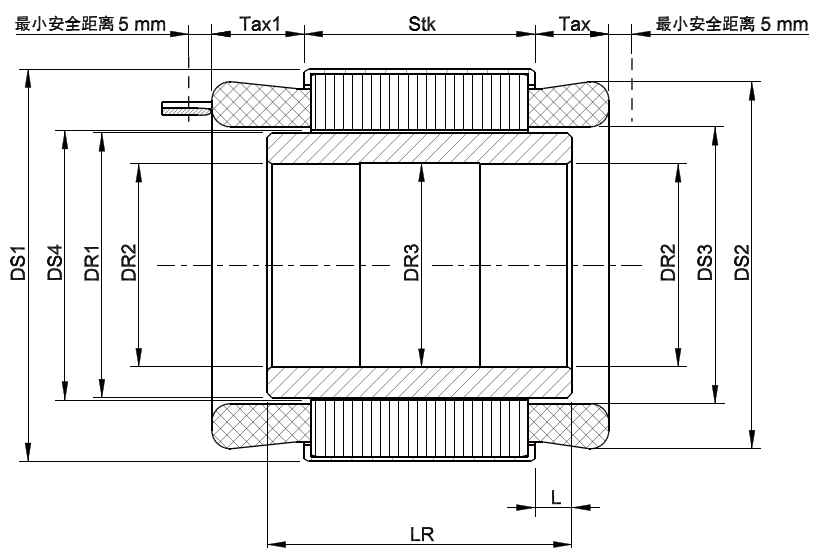

TK172

性能参数

电机型号 Motor Code	额定转速 Rated Speed	最大速度 Max Speed	额定电流 Rated Current	额定转矩 Rated Torque	额定功率 Rated Power	转矩常数 Torque Constant	最大电流 Max Current	最大转矩 Max Torque
	wn[rpm]	wmax[rpm]	In[A]	Tn [Nm]	Pn [kW]	Kt [Nm/A]	Imax [A]	Tmax [Nm]
TK172-050-015C	4100	5500	19.2	25	10.7	1.44	72	83
TK172-100-015C	4500	5500	43.4	56	26.4	1.44	144	166
TK172-180-011C	4700	18000	104	98.7	48.6	1.06	321	214
TK172-250-010C	6000	8000	154.8	127	79.8	0.95	493	284

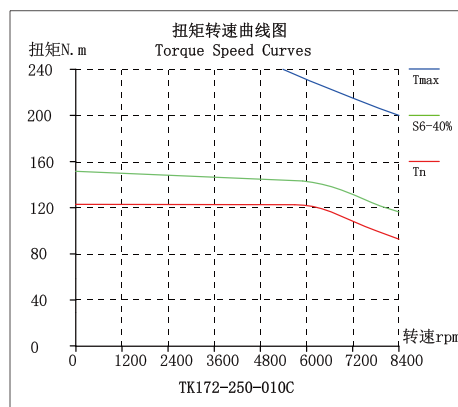
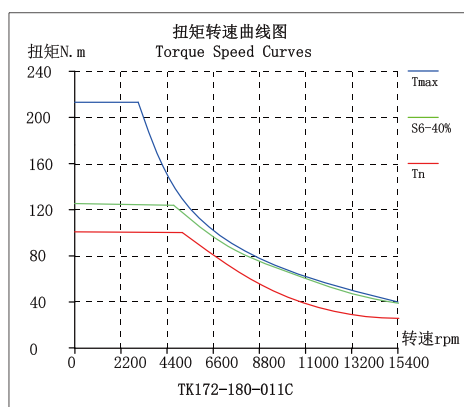

尺寸参数

电机型号 Motor Code	DS1	DS2	DS3	DS4	DR1	DR2	DR3	Stk	Tax1	Tax	LR	L
TK172-050-015C	175	160	117	115	113.8	30	31	53	38.5	28.5	70	8.5
TK172-100-015C	176	160	117	115	113.4	38	38	103	38.5	28.5	126	11.5
TK172-180-011C	176	160	117	115	113.4	96	96.5	183	35.5	28.5	196	6.5
TK172-250-010C	176	160	117	115	113.4	96	96.5	253	38.5	28.5	265	6

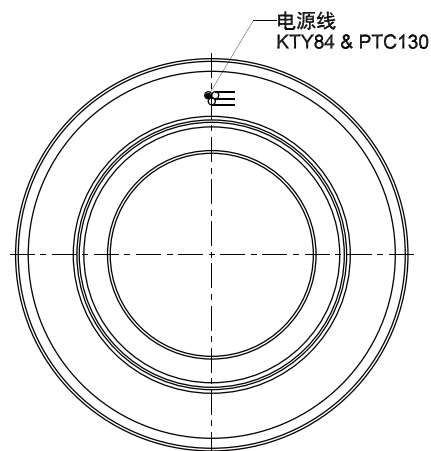
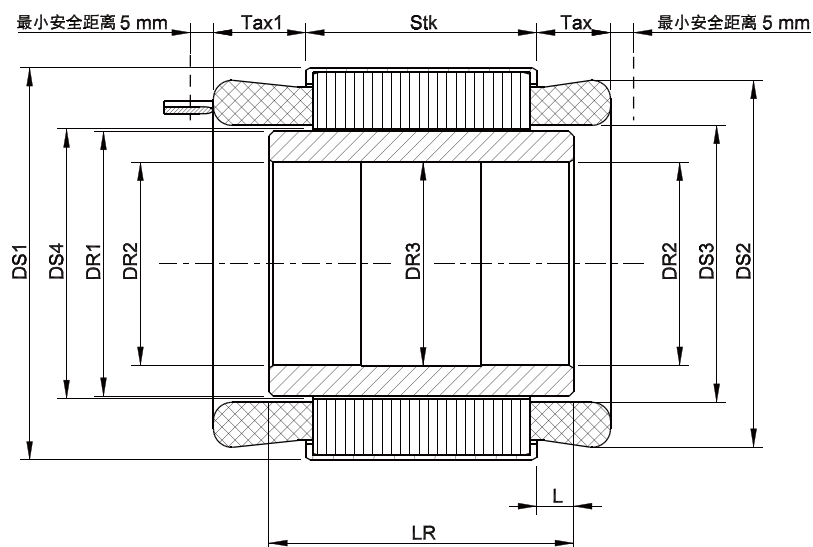

TK188

性能参数

电机型号 Motor Code	额定转速 Rated Speed	最大速度 Max Speed	额定电流 Rated Current	额定转矩 Rated Torque	额定功率 Rated Power	转矩常数 Torque Constant	最大电流 Max Current	最大转矩 Max Torque
	w_n [rpm]	w_{max} [rpm]	I_n [A]	T_n [Nm]	P_n [kW]	K_t [Nm/A]	I_{max} [A]	T_{max} [Nm]
TK188-100-029C	1500	6000	32	86	13.5	2.95	112	240
TK188-150-022C	2500	10000	52	126	27	2.21	219	359

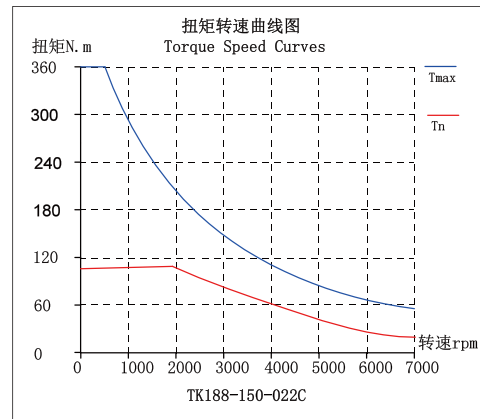
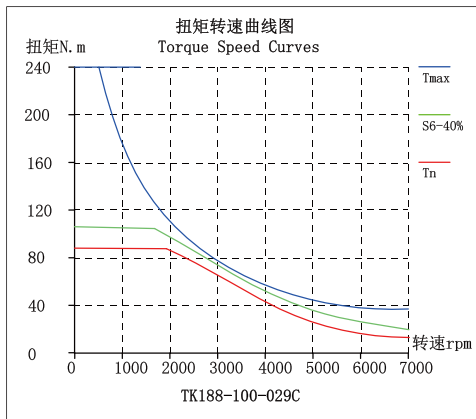

尺寸参数

电机型号 Motor Code	DS1	DS2	DS3	DS4	DR1	DR2	DR3	Stk	Tax1	Tax	LR	L
TK188-100-029C	191	175	135	130	128	96	97	103	33.5	25.5	113	5
TK188-150-022C	191	175	135	130	128	85	85	153	33.5	25.5	190	18.5

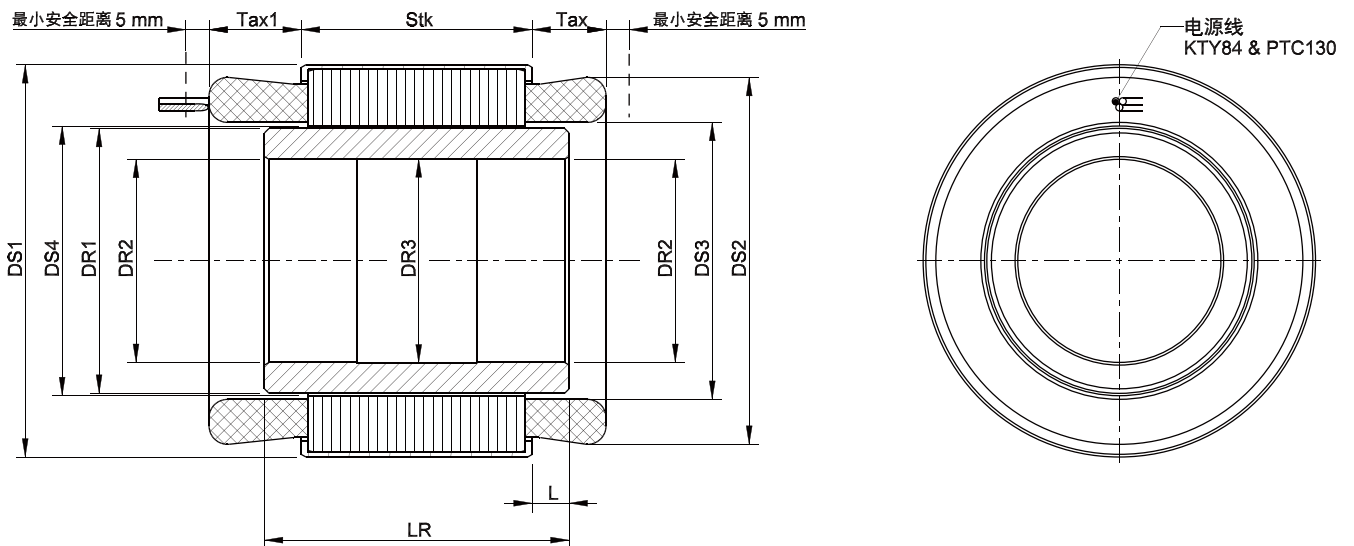

TK220

性能参数

电机型号 Motor Code	额定转速 Rated Speed	最大速度 Max Speed	额定电流 Rated Current	额定转矩 Rated Torque	额定功率 Rated Power	转矩常数 Torque Constant	最大电流 Max Current	最大转矩 Max Torque
	ω_n [rpm]	ω_{max} [rpm]	I_n [A]	T_n [Nm]	P_n [kW]	K_t [Nm/A]	I_{max} [A]	T_{max} [Nm]
TK220-050-023C	2000	5000	26.8	56	11.7	2.32	81	159
TK220-085-016C	1700	4500	96.7	133	23.7	1.59	289	368
TK220-085-027C	1500	5500	44.5	109.6	17.2	2.73	118	270
TK220-090-034C	1600	4000	46	155	26	3.4	105	286

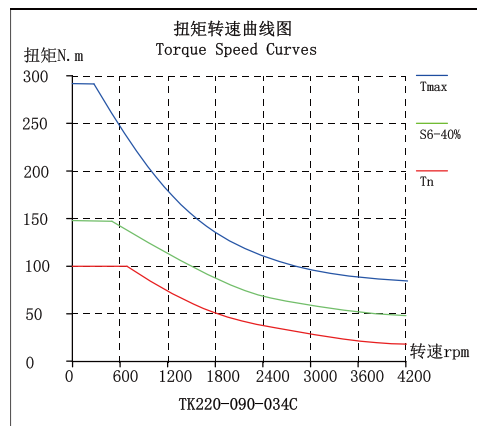
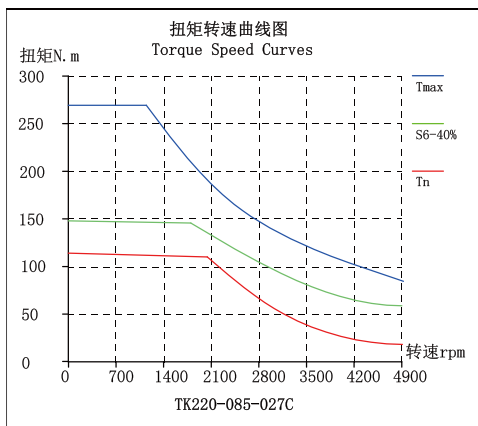
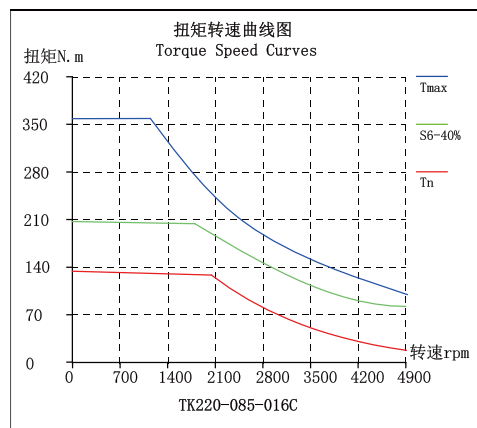
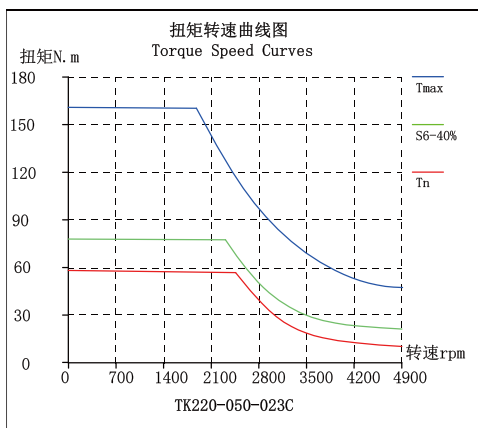

尺寸参数

电机型号 Motor Code	DS1	DS2	DS3	DS4	DR1	DR2	DR3	Stk	Tax1	Tax	LR	L
TK220-050-023C	223	200	153	150	148.8	110	110.5	53	26.5	22.5	65	6
TK220-085-016C	223	205	153	150	148.8	120	120.2	68	33.5	22.5	102	17
TK220-085-027C	223	205	153	150	148.8	110	110.5	88	26.5	22.5	100	6
TK220-090-034C	223	205	153	150	148.8	110	112	93	26.5	22.5	102	4.5

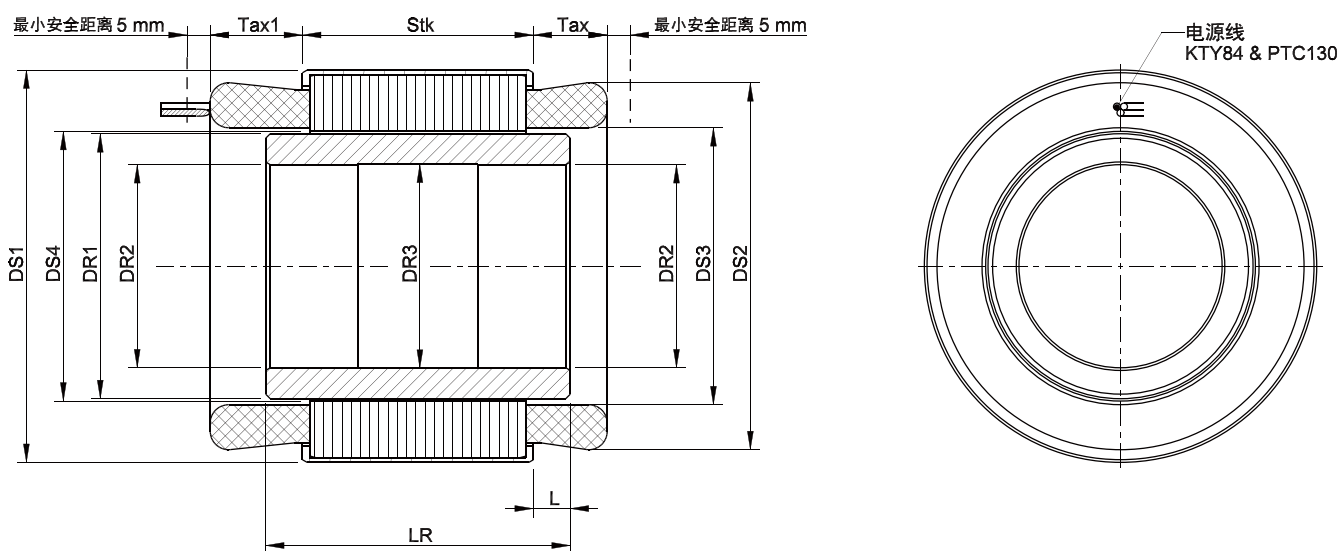

TK230

性能参数

电机型号 Motor Code	额定转速 Rated Speed	最大速度 Max Speed	额定电流 Rated Current	额定转矩 Rated Torque	额定功率 Rated Power	转矩常数 Torque Constant	最大电流 Max Current	最大转矩 Max Torque
	wn[rpm]	wmax[rpm]	In[A]	Tn [Nm]	Pn [kW]	Kt [Nm/A]	I _{max} [A]	T _{max} [Nm]
TK230-035-023C	1000	2500	35.4	71	7.4	2.29	78	143
TK230-040-10C	200	399	8	71.4	1.5	9.83	18	141
TK230-040-16A	120	439	2.7	39	0.5	15.84	13	163
TK230-050-17C	200	350	6.5	100	2.1	17.2	15	200
TK230-100-10C	400	669	22.7	203	8.5	10.12	52	409

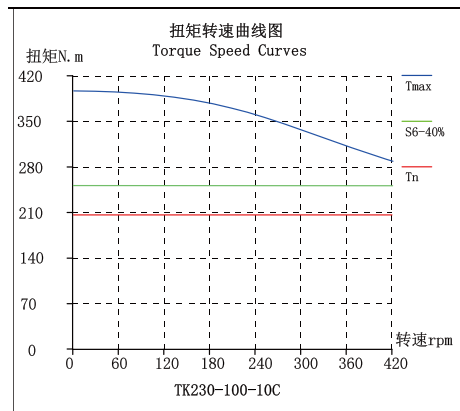
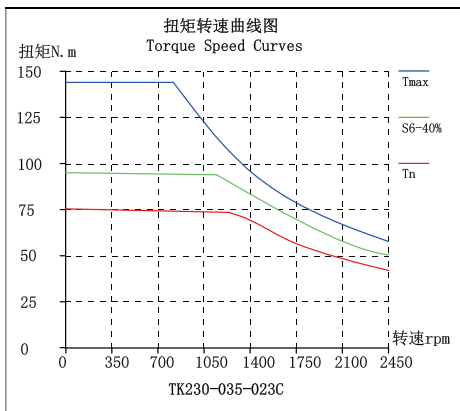

尺寸参数

电机型号 Motor Code	DS1	DS2	DS3	DS4	DR1	DR2	DR3	Stk	Tax1	Tax	LR	L
TK230-035-023C	221	213	173	170	168.8	140	140.5	38	19.5	14.5	54	8
TK230-040-10C	221	209	173	170	168.8	140	140.5	43	19.5	14.5	59	8
TK230-040-16A	218	213	173	170	168.8	139	140	40	21	16	53	6.5
TK230-050-17C	221	210	174	170	168.8	140	140.5	53	19.5	15.5	69	8
TK230-100-10C	221	210	174	170	168.8	140	141	103	19.5	14.5	112	4.5

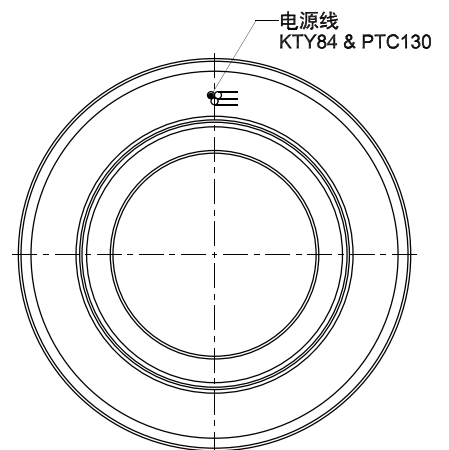
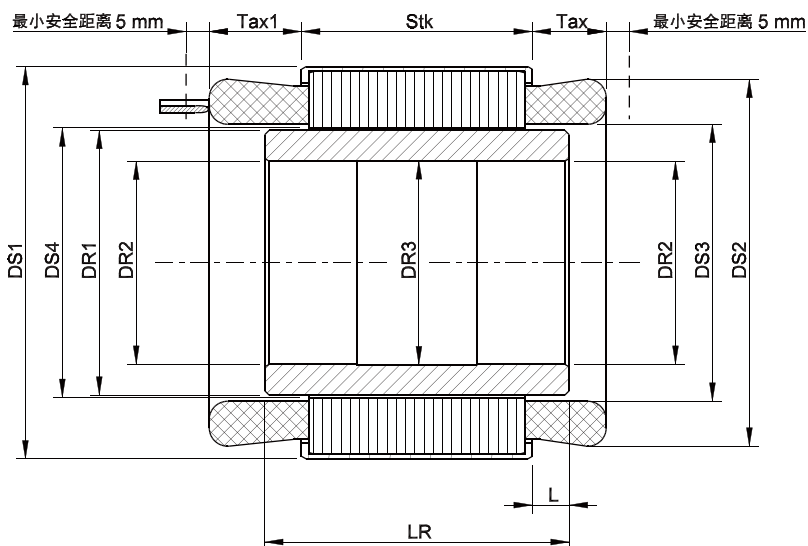

TK240

性能参数

电机型号 Motor Code	额定转速 Rated Speed	最大速度 Max Speed	额定电流 Rated Current	额定转矩 Rated Torque	额定功率 Rated Power	转矩常数 Torque Constant	最大电流 Max Current	最大转矩 Max Torque
	w_n [rpm]	w_{max} [rpm]	I_n [A]	T_n [Nm]	P_n [kW]	K_t [Nm/A]	I_{max} [A]	T_{max} [Nm]
TK240-070-017C	250	400	8	116	3	16.63	23	303
TK240-075-02C	3000	3224	50	92	28.8	2	220	337
TK240-110-02C	3000	3646	83	141	44.3	2	352	503
TK240-120-12C	300	560	21.8	234	7.4	12.05	54	520
TK240-140-04C	1150	4000	63.2	220	26.5	3.93	199	606

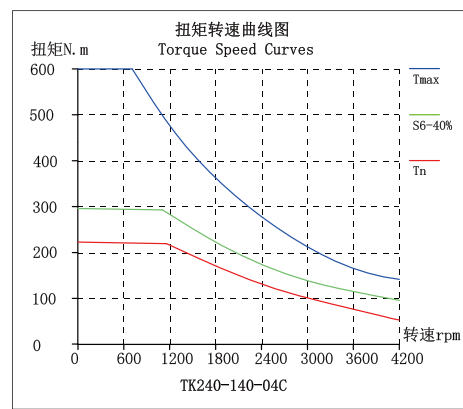
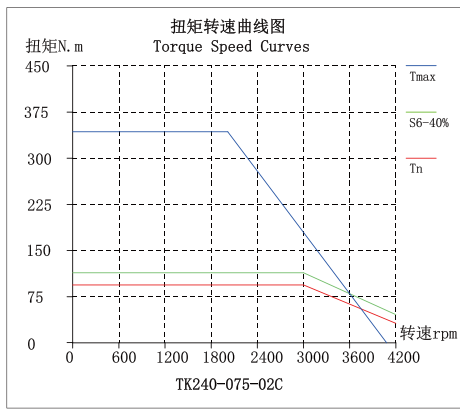

尺寸参数

电机型号 Motor Code	DS1	DS2	DS3	DS4	DR1	DR2	DR3	Stk	Tax1	Tax	LR	L
TK240-070-017C	241	228	179.4	175	173.4	139	140	73	28.5	22.5	86	6.5
TK240-075-02C	241	232	179.4	175	173.4	54	54	78	26	24	95.5	8.75
TK240-110-02C	241	228	179.4	175	173	106	107	113	32	22	130	8.5
TK240-120-12C	241	228	179.4	175	173.4	139	140	123	28.5	22.5	136	6.5
TK240-140-04C	241	226	180.4	175	173.4	140	141	143	28.5	22.5	156	6.5

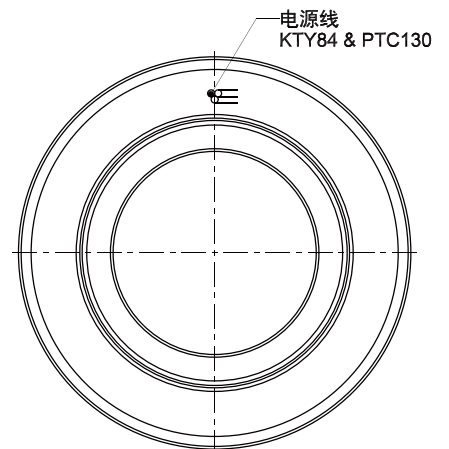
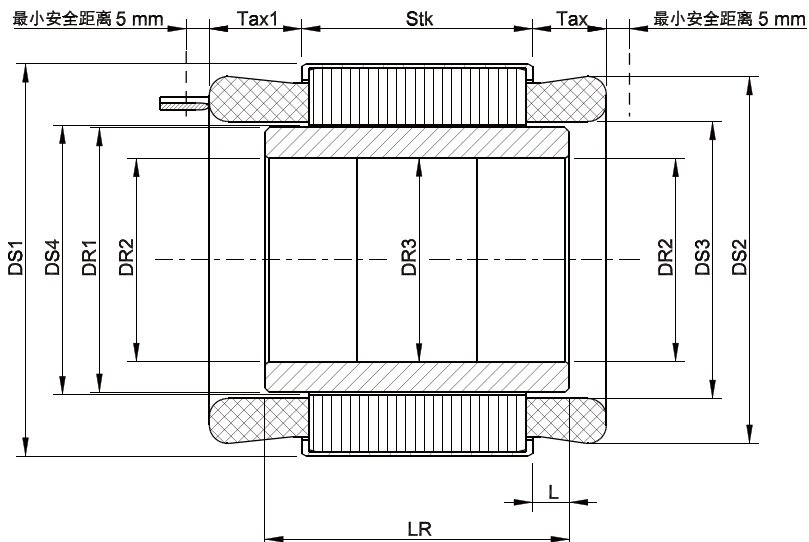

TK270

性能参数

电机型号 Motor Code	额定转速 Rated Speed	最大速度 Max Speed	额定电流 Rated Current	额定转矩 Rated Torque	额定功率 Rated Power	转矩常数 Torque Constant	最大电流 Max Current	最大转矩 Max Torque
	wn[rpm]	wmax[rpm]	In[A]	Tn [Nm]	Pn [kW]	Kt [Nm/A]	Imax [A]	Tmax [Nm]
TK270-080-06A	950	1140	18.5	95	9.5	5.73	99	452
TK270-140-28C	120	240	15.2	395	5	28.03	30	792
TK270-220-063C	700	3000	100.4	570	41.8	6.31	240	1046

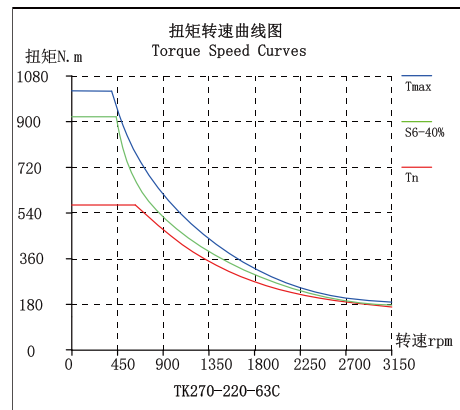
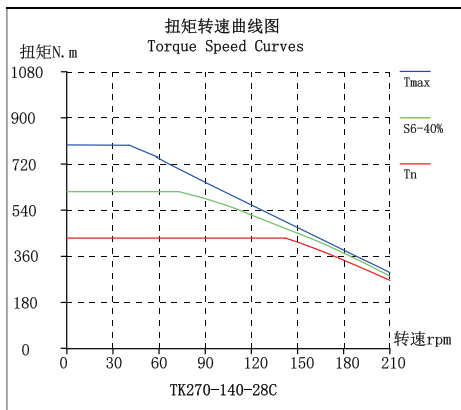

尺寸参数

电机型号 Motor Code	DS1	DS2	DS3	DS4	DR1	DR2	DR3	Stk	Tax1	Tax	LR	L
TK270-080-06A	269	254	203	200	198	120	121	80	33	23	100	10
TK270-140-28C	273	256	204	200	198	160	161	143	29.5	19.5	154	5.5
TK270-220-063C	273	256	204	200	198	160	161	223	35.5	22.5	234	5.5

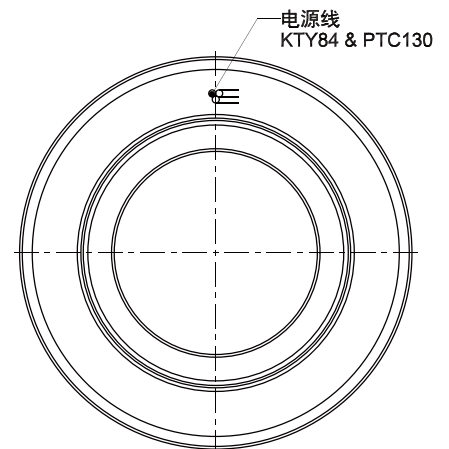
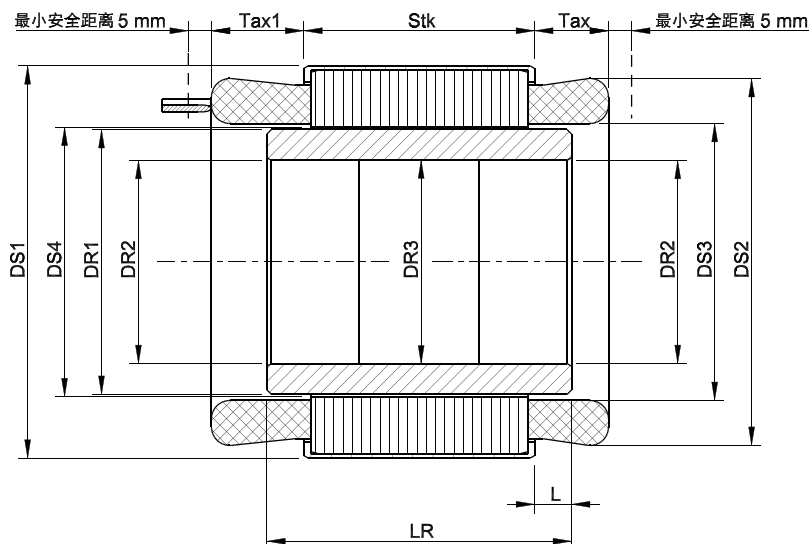

TK310

性能参数

电机型号 Motor Code	额定转速 Rated Speed	最大速度 Max Speed	额定电流 Rated Current	额定转矩 Rated Torque	额定功率 Rated Power	转矩常数 Torque Constant	最大电流 Max Current	最大转矩 Max Torque
	w_n [rpm]	w_{max} [rpm]	I_n [A]	T_n [Nm]	P_n [kW]	K_t [Nm/A]	I_{max} [A]	T_{max} [Nm]
TK310-035-15C	100	460	9.8	123.5	1.3	14.62	22	242
TK310-070-15C	275	430	20.7	279	8	15.57	39	480
TK310-160-45C	78	150	19.1	780	6.4	45.09	30	1064

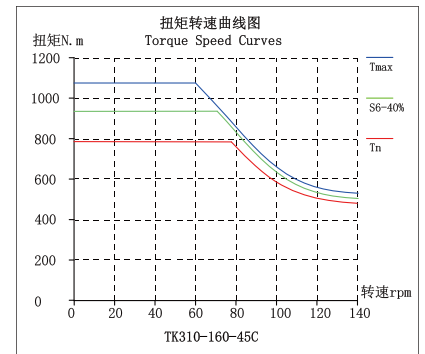
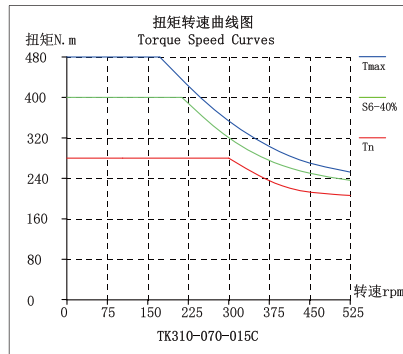
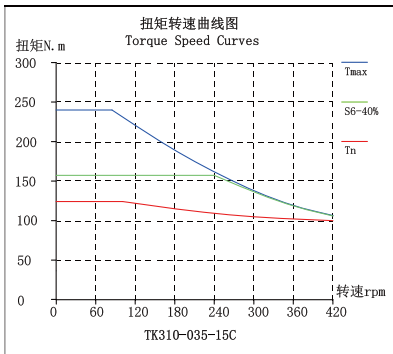

尺寸参数

电机型号 Motor Code	DS1	DS2	DS3	DS4	DR1	DR2	DR3	Stk	Tax1	Tax	LR	L
TK310-035-15C	295.5	284	234	230	228.6	199	200	39	20	17	52	6.5
TK310-070-15C	295.5	284	234	230	228.6	200	200.6	72	20	17	90	9
TK310-160-45C	295.5	284	234	230	229.2	199	200	164	20	17	177	6.5

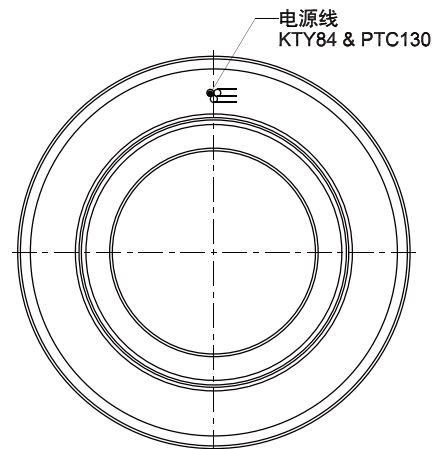
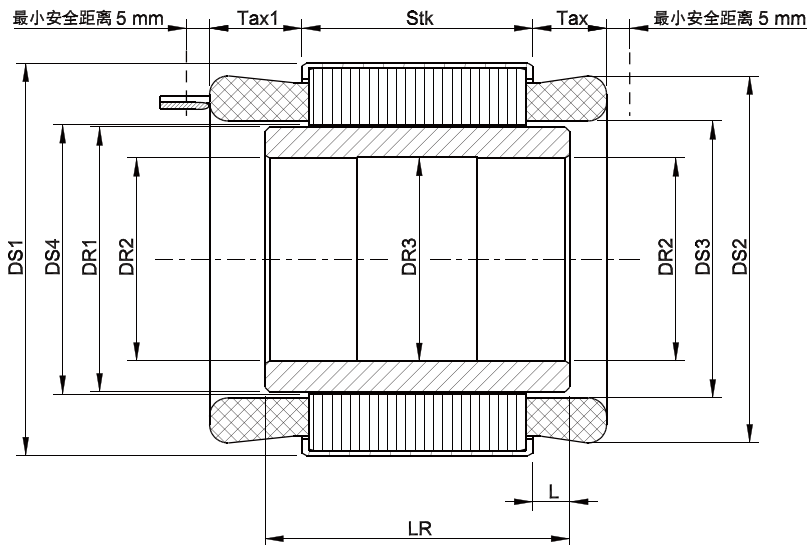

TK340

性能参数

电机型号 Motor Code	额定转速 Rated Speed	最大速度 Max Speed	额定电流 Rated Current	额定转矩 Rated Torque	额定功率 Rated Power	转矩常数 Torque Constant	最大电流 Max Current	最大转矩 Max Torque
	w_n [rpm]	w_{max} [rpm]	I_n [A]	T_n [Nm]	P_n [kW]	K_t [Nm/A]	I_{max} [A]	T_{max} [Nm]
TK340-095-11A	500	610	15.4	156	8.2	11	97	774
TK340-105-05C	750	1171	82.4	419	32.9	5.48	204	896

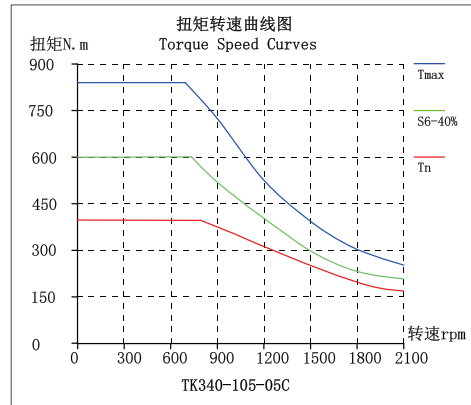
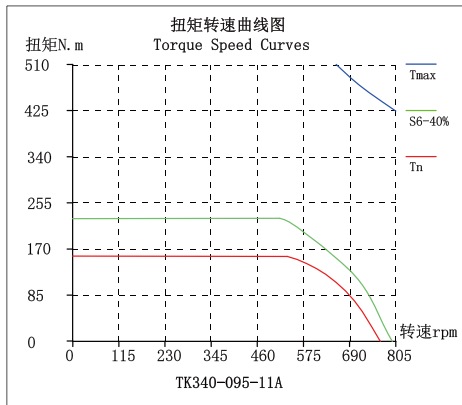

尺寸参数

电机型号 Motor Code	DS1	DS2	DS3	DS4	DR1	DR2	DR3	Stk	Tax1	Tax	LR	L
TK340-095-11A	341	315.5	243.5	240	238.6	207	208	99	34	26	116	8.5
TK340-105-05C	341	315.5	243.5	240	238.6	210	211	114	38	23	120	3

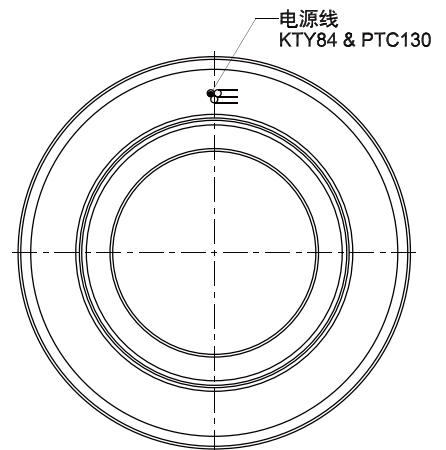
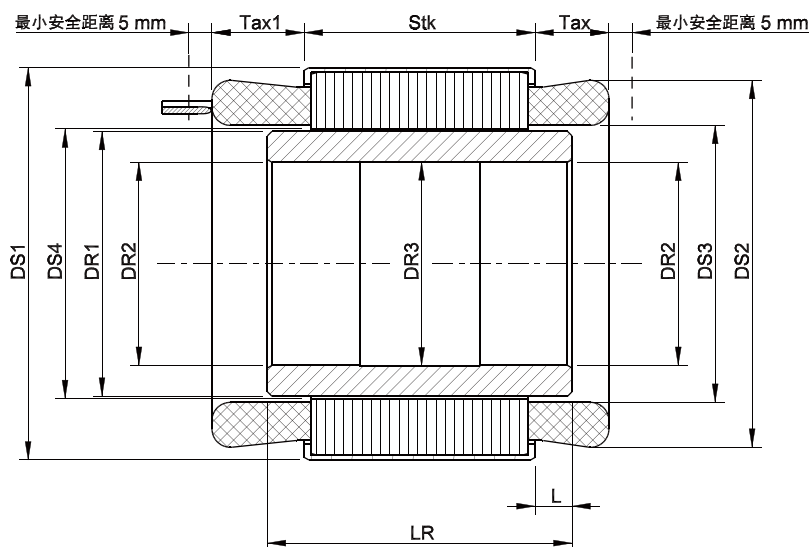

TK360

性能参数

电机型号 Motor Code	额定转速 Rated Speed	最大速度 Max Speed	额定电流 Rated Current	额定转矩 Rated Torque	额定功率 Rated Power	转矩常数 Torque Constant	最大电流 Max Current	最大转矩 Max Torque
	wn[rpm]	wmax[rpm]	In[A]	Tn [Nm]	Pn [kW]	Kt [Nm/A]	Imax [A]	Tmax [Nm]
TK360-130-36C	100	200	24.4	768	8	36.05	59	1694
TK360-140-09C	580	745	94.7	758	46	9.09	192	1474
TK360-160-18Y	300	380	47.5	723	22.7	17.62	113	1711
TK360-270-21C	245	300	58.4	1150	29.5	21.38	147	2719
TK360-300-18C	250	300	95	1549	40.5	18.2	207	3207
TK360-400-32C	200	211	78	1919	40.2	31.76	160	4276

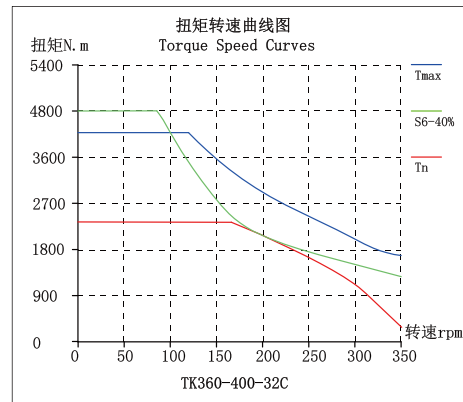
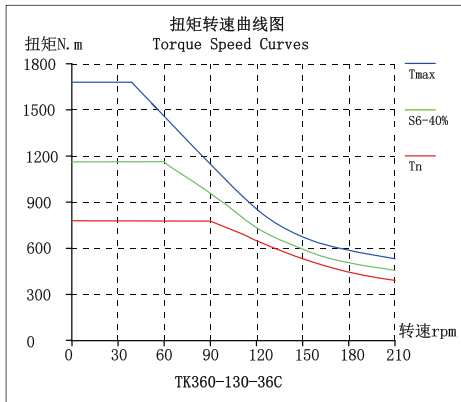

尺寸参数

电机型号 Motor Code	DS1	DS2	DS3	DS4	DR1	DR2	DR3	Stk	Tax1	Tax	LR	L
TK360-130-36C	360	344	279	275	273.6	220	222	130	30	18	146	8
TK360-140-09C	360	344	279	275	273.6	261	261.5	144	30	18	166	11
TK360-160-18Y	360	344	279	275	273.6	237	235	164	36	18	180	8
TK360-270-21C	360	344	279	275	273.6	237	235	274	36	18	300	13
TK360-300-18C	360	344	279	275	273.6	236	234	304	36	18	322	9
TK360-400-32C	360	344	279	275	273.6	238	240	404	36	18	406	1

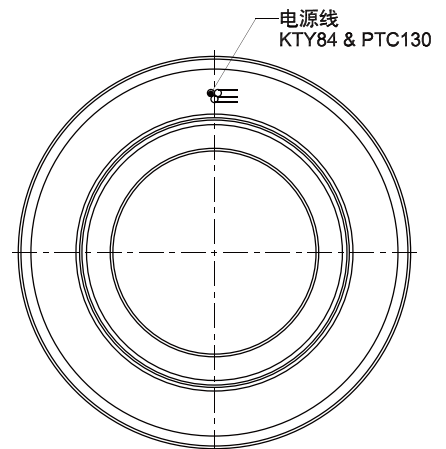
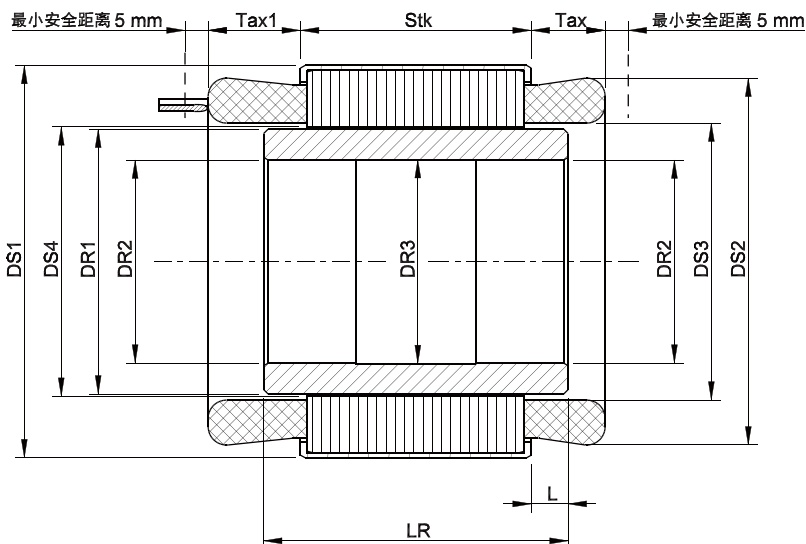

TK370

性能参数

电机型号 Motor Code	额定转速 Rated Speed	最大速度 Max Speed	额定电流 Rated Current	额定转矩 Rated Torque	额定功率 Rated Power	转矩常数 Torque Constant	最大电流 Max Current	最大转矩 Max Torque
	w_n [rpm]	w_{max} [rpm]	I_n [A]	T_n [Nm]	P_n [kW]	K_t [Nm/A]	I_{max} [A]	T_{max} [Nm]
TK370-170-30C	100	430	45.3	1200	12.6	31.23	76	2122
TK370-170-70A	60	120	16	615	3.9	40.66	54	2137
TK370-260-11C	370	533	147	1631	63.2	12.04	343	3308
TK370-260-33C	100	250	61.7	1536	16.1	26.87	134	3308

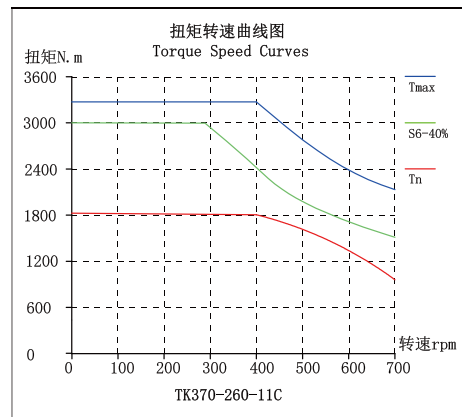
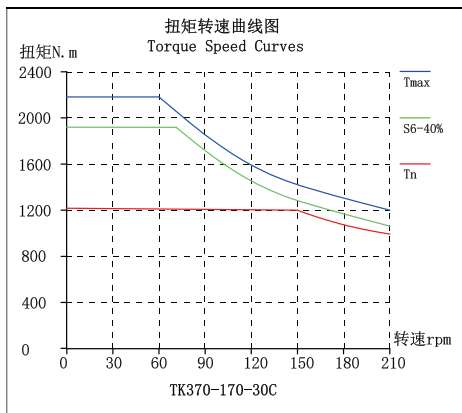

尺寸参数

电机型号 Motor Code	DS1	DS2	DS3	DS4	DR1	DR2	DR3	Stk	Tax1	Tax	LR	L
TK370-170-30C	374	356	304	300	294.4	265	265.6	174	25	19	195	10.5
TK370-170-70A	370	356	304	300	298.4	265	265.6	170	27	21	195	12.5
TK370-260-11C	370	358	304	300	298.4	263	264	264	36	23	284	10
TK370-260-33C	370	354	304	300	298.4	242	243	264	30	18	284	10

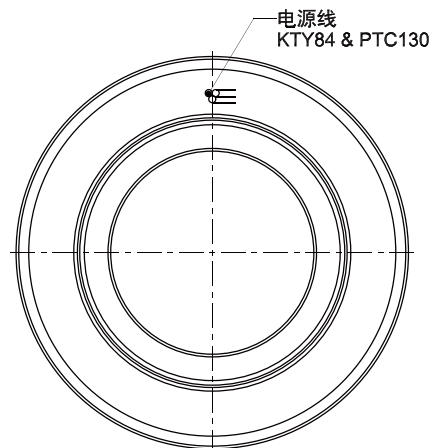
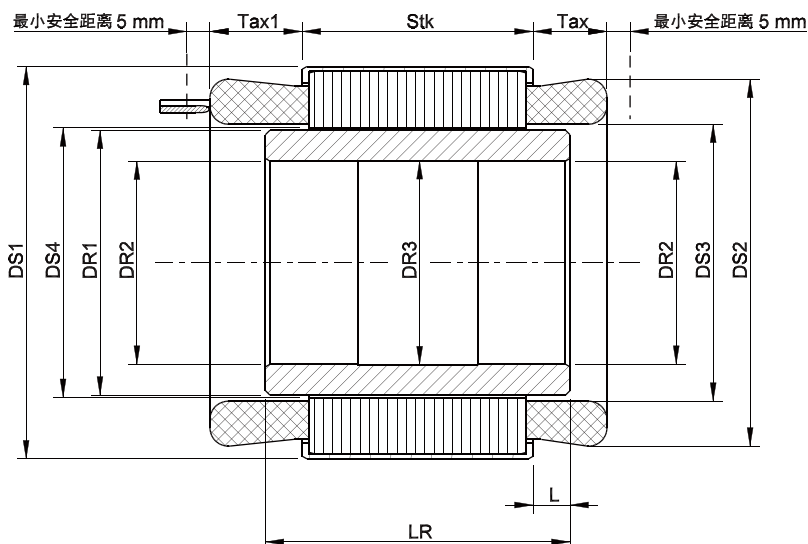

TK440

性能参数

电机型号 Motor Code	额定转速 Rated Speed	最大速度 Max Speed	额定电流 Rated Current	额定转矩 Rated Torque	额定功率 Rated Power	转矩常数 Torque Constant	最大电流 Max Current	最大转矩 Max Torque
	wn[rpm]	wmax[rpm]	In[A]	Tn [Nm]	Pn [kW]	Kt [Nm/A]	Imax [A]	Tmax [Nm]
TK440-050-40C	100	200	12.1	440	4.6	40.52	26	858
TK440-130-80C	45	60	17.8	1260	5.9	79.01	28	2200

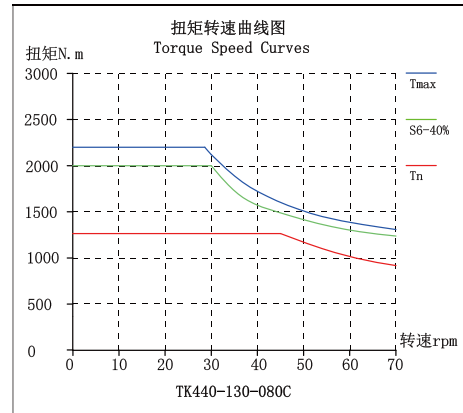
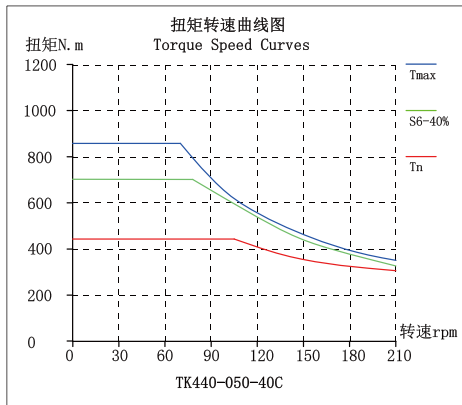

尺寸参数

电机型号 Motor Code	DS1	DS2	DS3	DS4	DR1	DR2	DR3	Stk	Tax1	Tax	LR	L
TK440-050-40C	416	352	408	348	346.4	300	302	50	19	12	75	12.5
TK440-130-80C	416	352	408	348	346.4	334.3	300	126	21	12	183	28.5

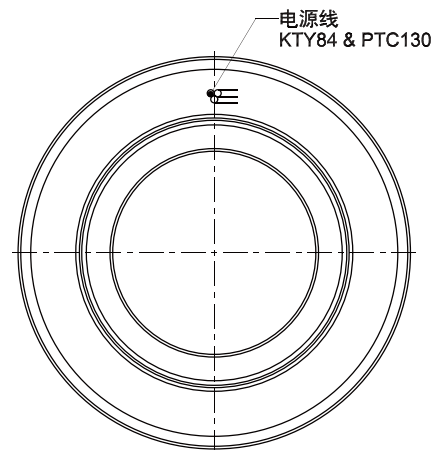
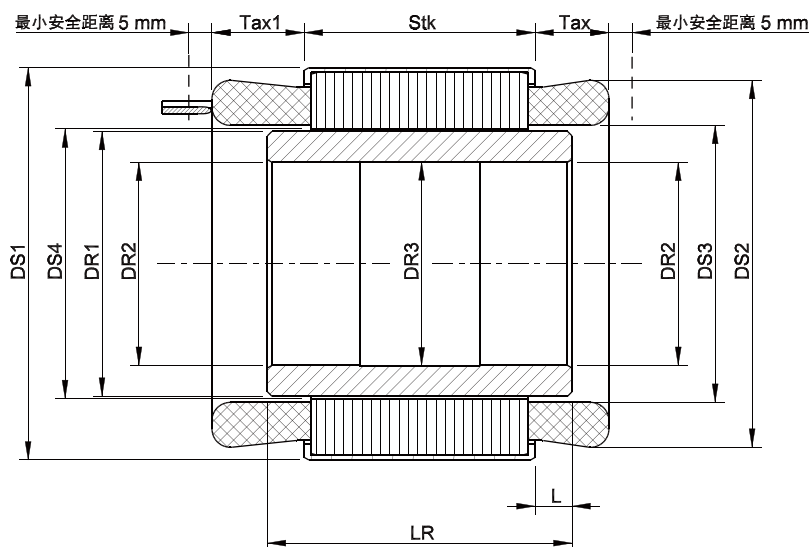

TK450

性能参数

电机型号 Motor Code	额定转速 Rated Speed	最大速度 Max Speed	额定电流 Rated Current	额定转矩 Rated Torque	额定功率 Rated Power	转矩常数 Torque Constant	最大电流 Max Current	最大转矩 Max Torque
	wn[rpm]	wmax[rpm]	In[A]	Tn [Nm]	Pn [kW]	Kt [Nm/A]	Imax [A]	Tmax [Nm]
TK450-140-54C	70	125	27	1321	9.7	54.17	53	2575
TK450-200-093C	650	800	235	1960	133.4	9.3	260	3872
TK450-240-15C	300	420	166.7	2299	72.2	15.79	516	4886
TK450-300-12C	474	578	335	2678	168.27	11.73	586	5497
TK450-440-14C	450	700	303.7	3945	185.9	14.35	880	9469

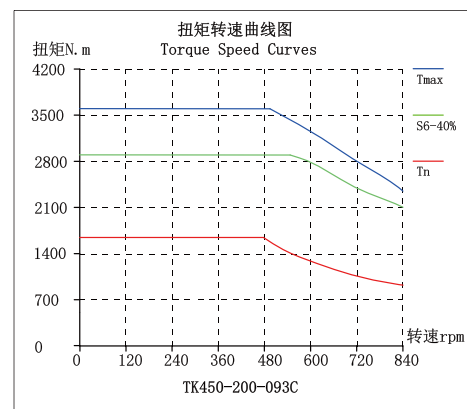
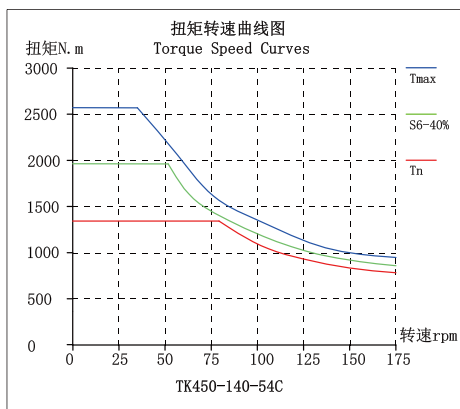

尺寸参数

电机型号 Motor Code	DS1	DS2	DS3	DS4	DR1	DR2	DR3	Stk	Tax1	Tax	LR	L
TK450-140-54C	450	430	364	360	358	315	316	144	31	23	160	8
TK450-200-093C	450	430	364	360	358	321	321.5	204	43	27	250	23
TK450-240-15C	450	432	363	360	358	321	321.5	244	39	25	280	18
TK450-300-12C	450	430	364	360	358	321	321.5	304	33	25	350	23
TK450-440-14C	450	432	363	360	358	316	313	443	44.5	25.5	460	8.5

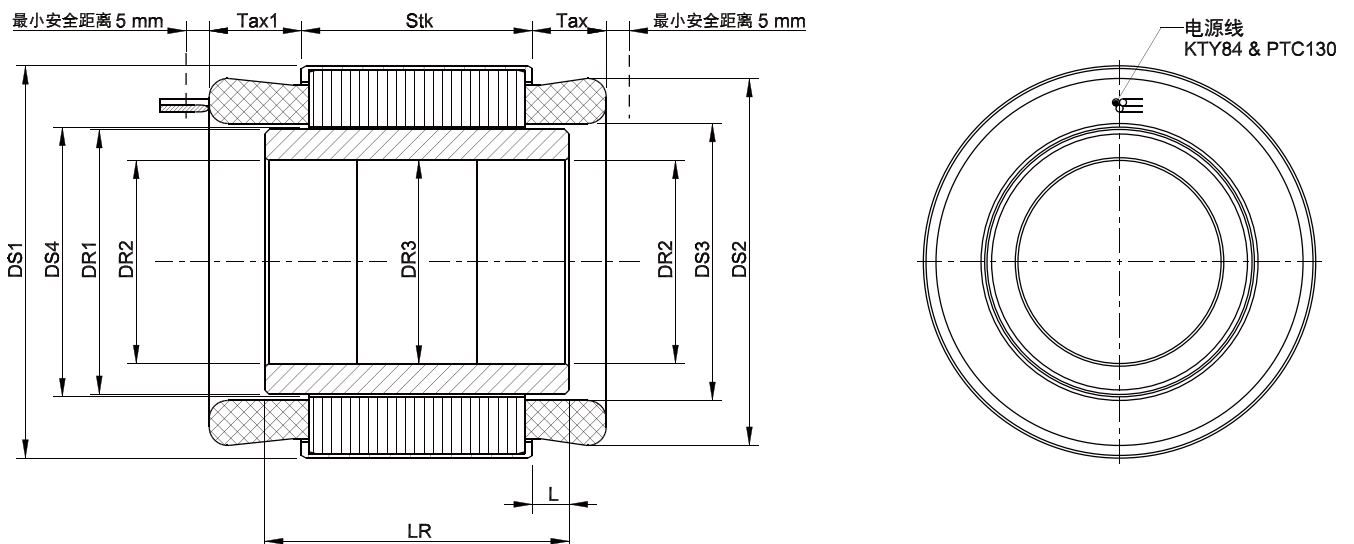

TK540

性能参数

电机型号 Motor Code	额定转速 Rated Speed	最大速度 Max Speed	额定电流 Rated Current	额定转矩 Rated Torque	额定功率 Rated Power	转矩常数 Torque Constant	最大电流 Max Current	最大转矩 Max Torque
	ω_n [rpm]	ω_{max} [rpm]	I_n [A]	T_n [Nm]	P_n [kW]	K_t [Nm/A]	I_{max} [A]	T_{max} [Nm]
TK540-140-44C	100	150	51	2020	21.2	44.41	109	4008
TK540-190-23C	250	290	130	2604	68.18	23.08	287	5439

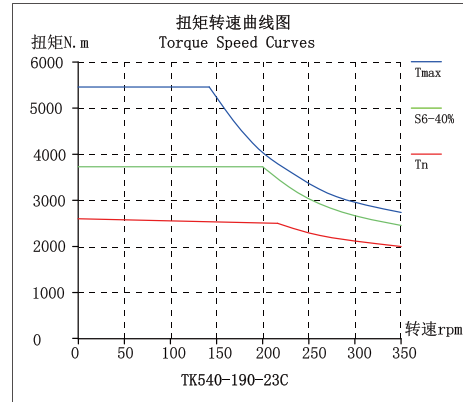
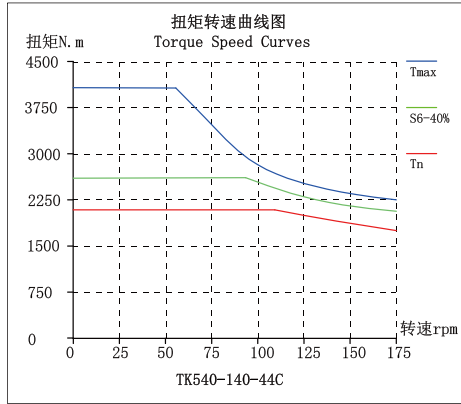

尺寸参数

电机型号 Motor Code	DS1	DS2	DS3	DS4	DR1	DR2	DR3	Stk	Tax1	Tax	LR	L
TK540-140-44C	541	517	453	450	447.6	406	407	144	38	23	160	8
TK540-190-23C	541	517	453	450	447.6	410	410.5	194	39	23	212	9

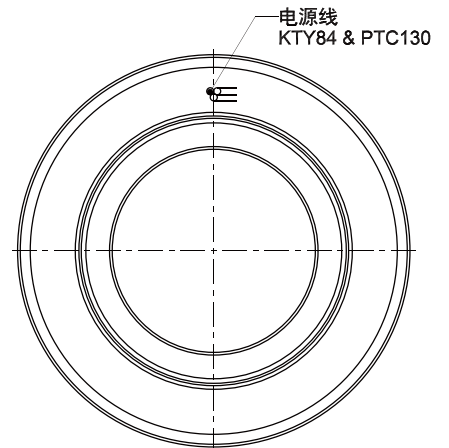
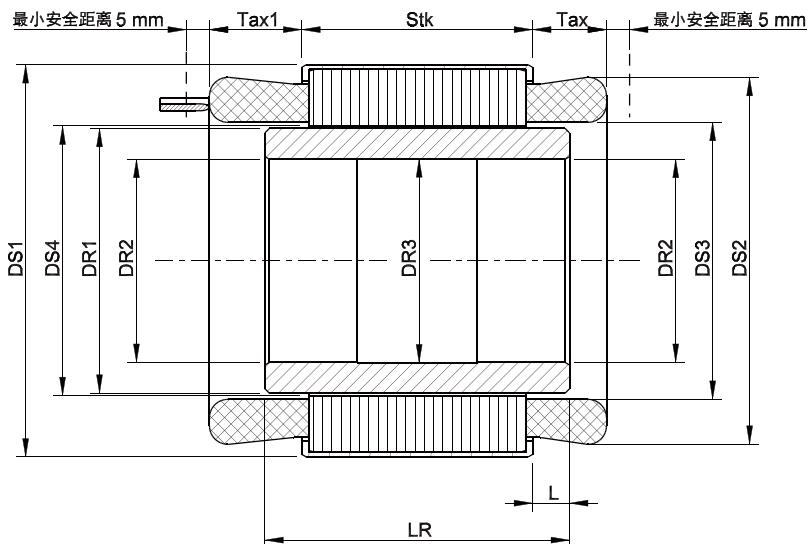

TK570

性能参数

电机型号 Motor Code	额定转速 Rated Speed	最大速度 Max Speed	额定电流 Rated Current	额定转矩 Rated Torque	额定功率 Rated Power	转矩常数 Torque Constant	最大电流 Max Current	最大转矩 Max Torque
	ω_n [rpm]	ω_{max} [rpm]	I_n [A]	T_n [Nm]	P_n [kW]	K_t [Nm/A]	I_{max} [A]	T_{max} [Nm]
TK570-080-36C	100	185	31.4	1063	11.1	36.52	104	2827
TK570-550-25C	250	450	313	7192	188.3	24.63	1300	22000

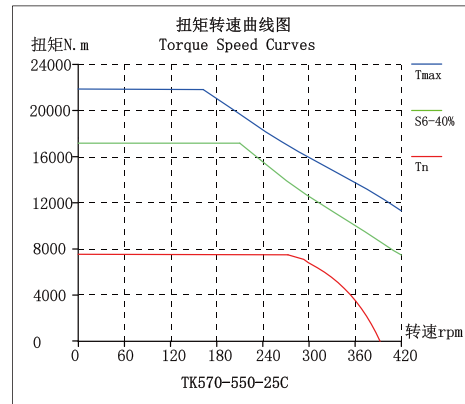
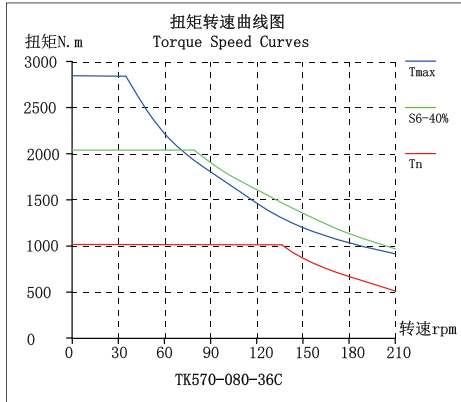

尺寸参数

电机型号 Motor Code	DS1	DS2	DS3	DS4	DR1	DR2	DR3	Stk	Tax1	Tax	LR	L
TK570-080-36C	571	550	503	500	498.2	445	447	84	23	16	100	8
TK570-550-25C	571	550	503	500	498.6	450	447	554	38	23	590	18

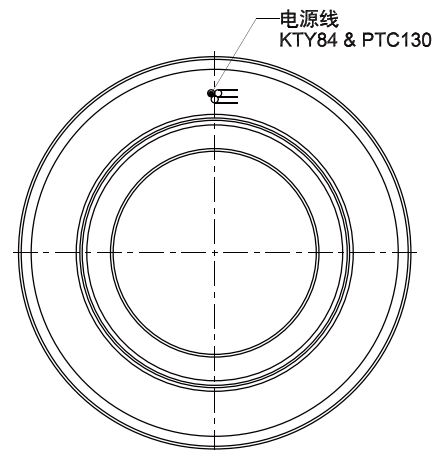
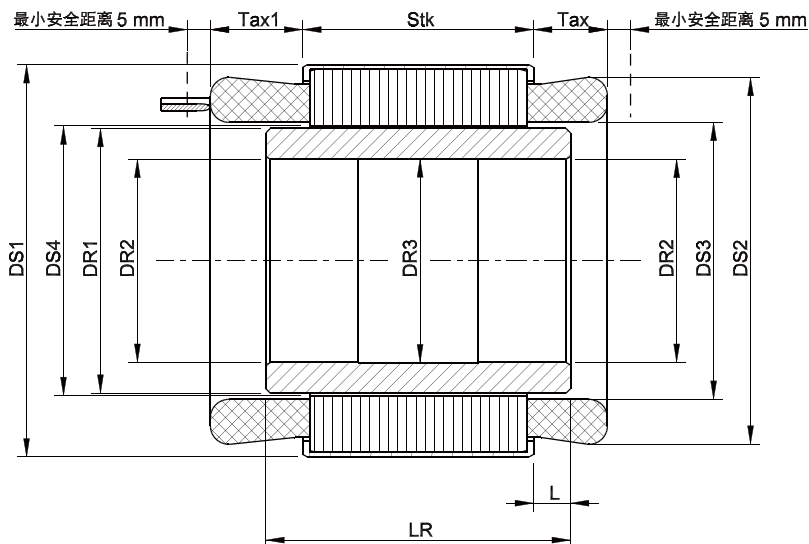

TK615

性能参数

电机型号 Motor Code	额定转速 Rated Speed	最大速度 Max Speed	额定电流 Rated Current	额定转矩 Rated Torque	额定功率 Rated Power	转矩常数 Torque Constant	最大电流 Max Current	最大转矩 Max Torque
	w_n [rpm]	w_{max} [rpm]	I_n [A]	T_n [Nm]	P_n [kW]	K_t [Nm/A]	I_{max} [A]	T_{max} [Nm]
TK615-260-21C	250	400	274	5430	142.2	20.72	780	15390
TK615-500-39Y	150	201	250	8452	132.8	39.07	528	15306

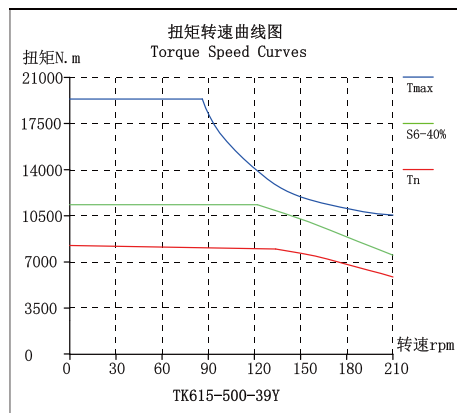
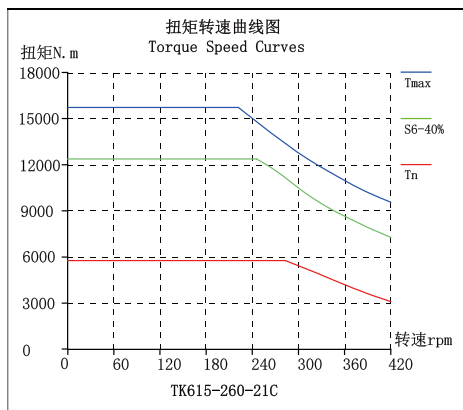

尺寸参数

电机型号 Motor Code	DS1	DS2	DS3	DS4	DR1	DR2	DR3	Stk	Tax1	Tax	LR	L
TK615-260-21C	615	591	539	534.8	532.2	200	201	260	38	28	280	10
TK615-500-39Y	615	591	539	534.8	532.2	497	494	504	38	28	510	3

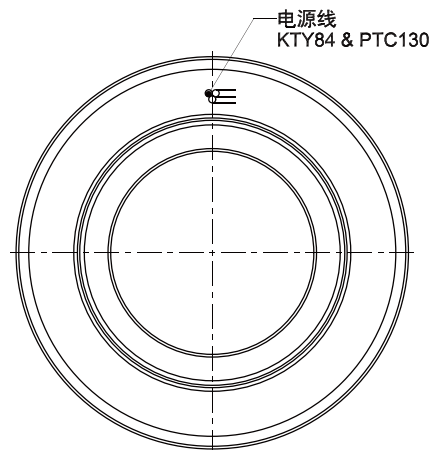
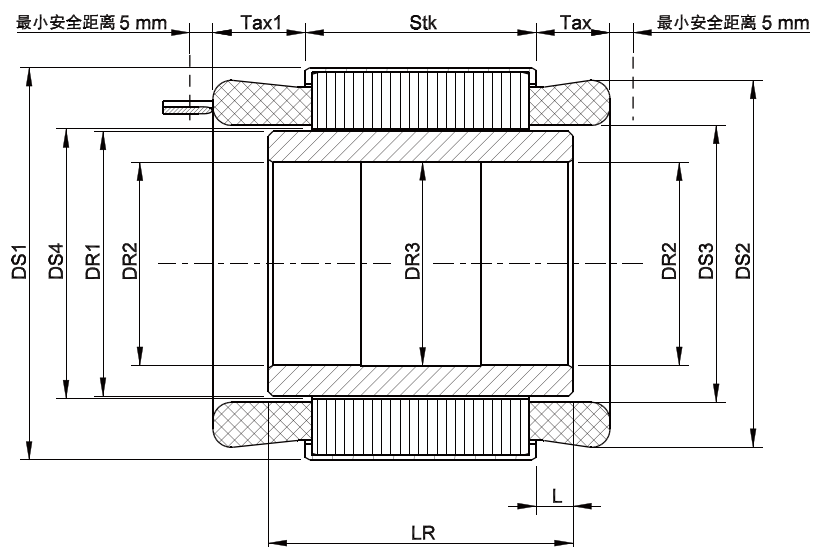

TK795

性能参数

电机型号 Motor Code	额定转速 Rated Speed	最大速度 Max Speed	额定电流 Rated Current	额定转矩 Rated Torque	额定功率 Rated Power	转矩常数 Torque Constant	最大电流 Max Current	最大转矩 Max Torque
	w_n [rpm]	w_{max} [rpm]	I_n [A]	T_n [Nm]	P_n [kW]	K_t [Nm/A]	I_{max} [A]	T_{max} [Nm]
TK795-134-68C	60	500	86.8	4806	30.2	66.65	166	8294

尺寸参数

电机型号 Motor Code	DS1	DS2	DS3	DS4	DR1	DR2	DR3	Stk	Tax1	Tax	LR	L
TK795-134-68C	571	550	503	500	498.2	445	447	84	23	16	100	8

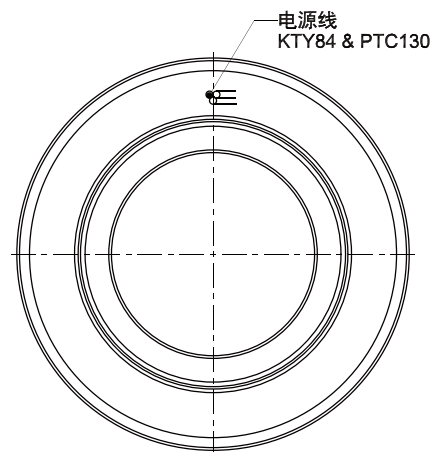
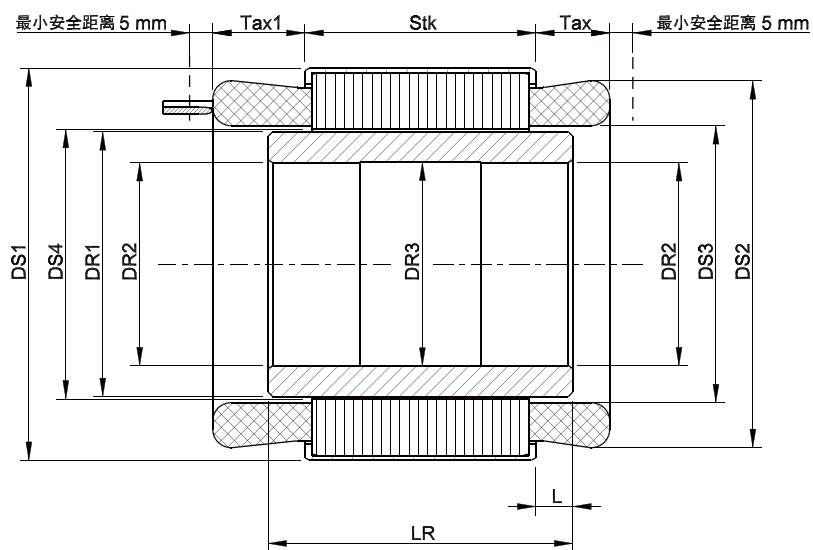

TK795

性能参数

电机型号 Motor Code	额定转速 Rated Speed	最大速度 Max Speed	额定电流 Rated Current	额定转矩 Rated Torque	额定功率 Rated Power	转矩常数 Torque Constant	最大电流 Max Current	最大转矩 Max Torque
	wn[rpm]	wmax[rpm]	In[A]	Tn [Nm]	Pn [kW]	Kt [Nm/A]	Imax [A]	Tmax [Nm]
TK795-120-95C	50	90	53	4700	24.6	92.8	200	10200
TK795-230-16C	450	900	454	6500	306.3	15.65	1103	15481
TK795-450-48C	100	140	360	15236	159.6	47.6	763	30288

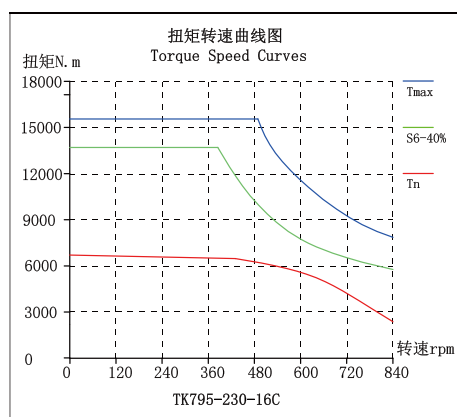
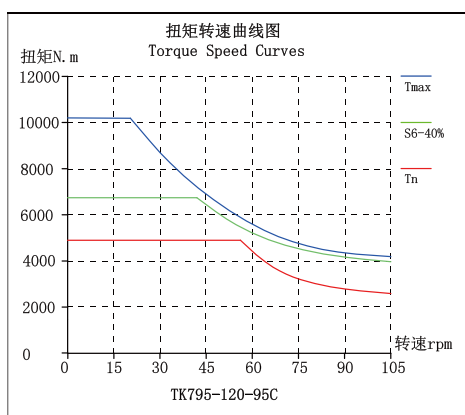

尺寸参数

电机型号 Motor Code	DS1	DS2	DR1	DR2	DR3	LS	LR	L
TK795-120-95C	825	690	686.8	630	631	215	154	30.5
TK795-230-16C	827	690	686.8	600	602	230	265	17.5
TK795-450-48C	830	690	686.8	650	652	600	466	82

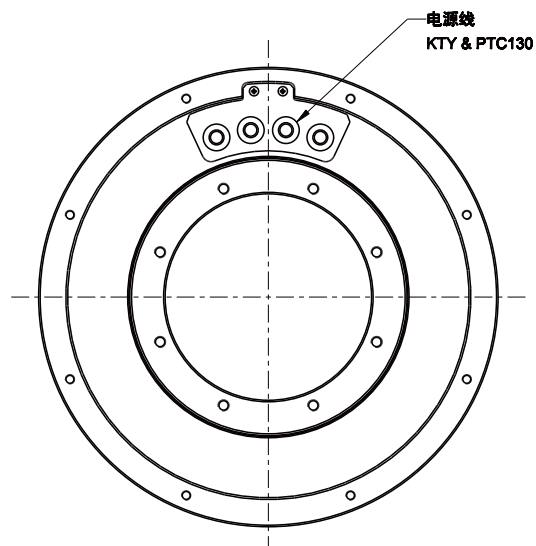
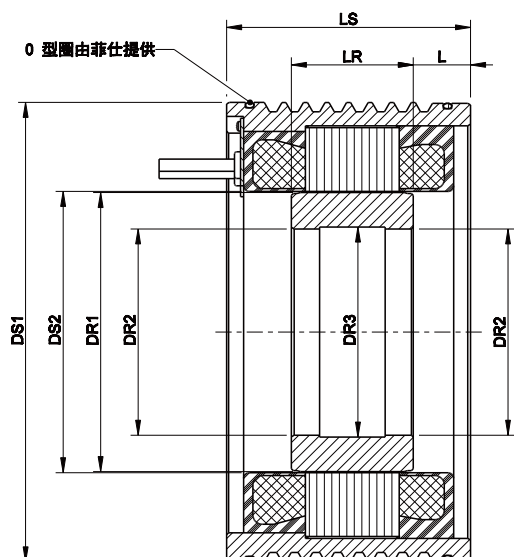

TK1000

性能参数

电机型号 Motor Code	额定转速 Rated Speed	最大速度 Max Speed	额定电流 Rated Current	额定转矩 Rated Torque	额定功率 Rated Power	转矩常数 Torque Constant	最大电流 Max Current	最大转矩 Max Torque
	w_n [rpm]	w_{max} [rpm]	I_n [A]	T_n [Nm]	P_n [kW]	K_t [Nm/A]	I_{max} [A]	T_{max} [Nm]
TK1000-250-295A	3	11	10.22	2839.13	0.99	295.45	64	14522
TK1000-480-22C	320	/	1293	25733	758	22.45	3000	57247

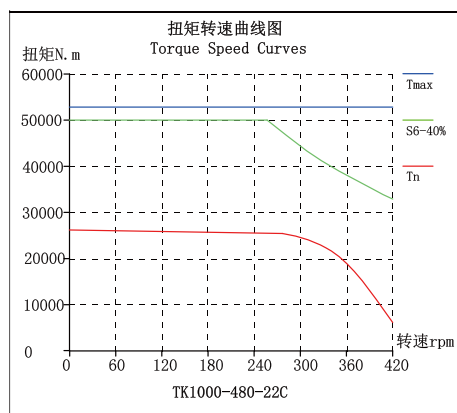
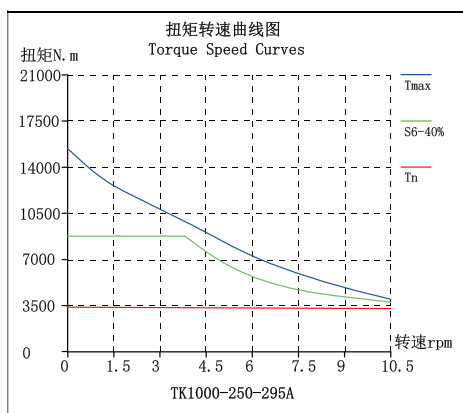

尺寸参数

电机型号 Motor Code	DS1	DS2	DR1	DR2	DR3	LS	LR	L
TK1000-250-295A	1050	920	916.8	840	838	337	270	33.5
TK1000-480-22C	1060	870	866.7	745	735	640	518	61

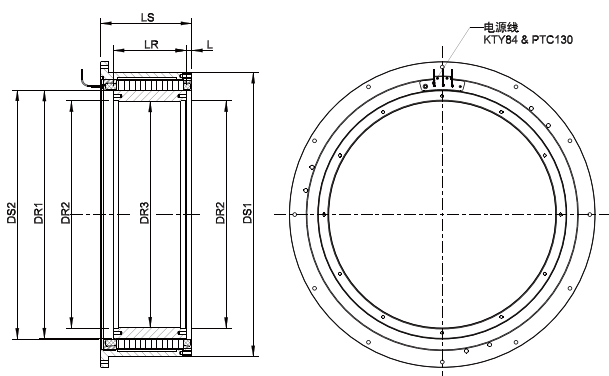

TK1000-250-295A

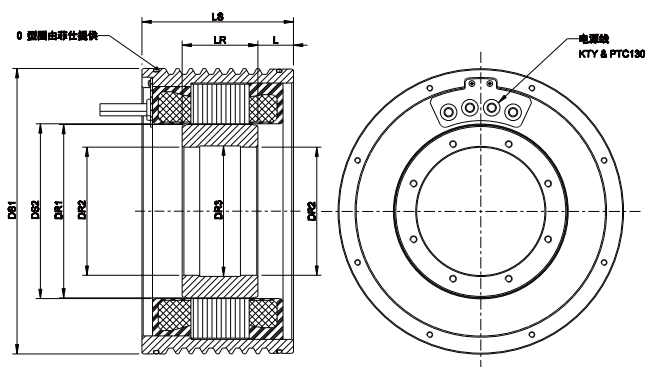

TK1000-480-22C

TK1280

性能参数

电机型号 Motor Code	额定转速 Rated Speed	最大速度 Max Speed	额定电流 Rated Current	额定转矩 Rated Torque	额定功率 Rated Power	转矩常数 Torque Constant	最大电流 Max Current	最大转矩 Max Torque
	ω_n [rpm]	ω_{max} [rpm]	I_n [A]	T_n [Nm]	P_n [kW]	K_t [Nm/A]	I_{max} [A]	T_{max} [Nm]
TK1280-460-255A	10	19	35.72	8184.29	8.57	232.68	141	25253
TK1280-280-186A	10	24	21.25	3907.86	4.09	186.14	141	20203

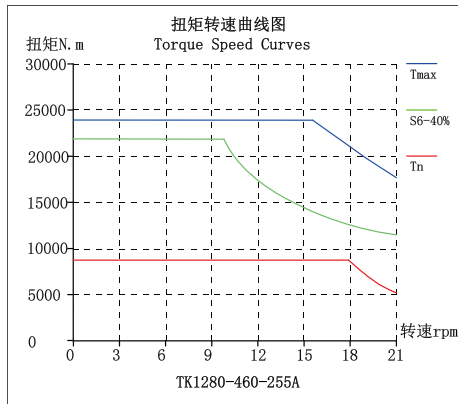

尺寸参数

电机型号 Motor Code	DS1	DS2	DR1	DR2	DR3	LS	LR	L
TK1280-460-255A	1340	1170	1166.6	1002	1000	610	645	17.5
TK1280-280-186A	1340	1170	1166.6	1002	1000	430	465	17.5

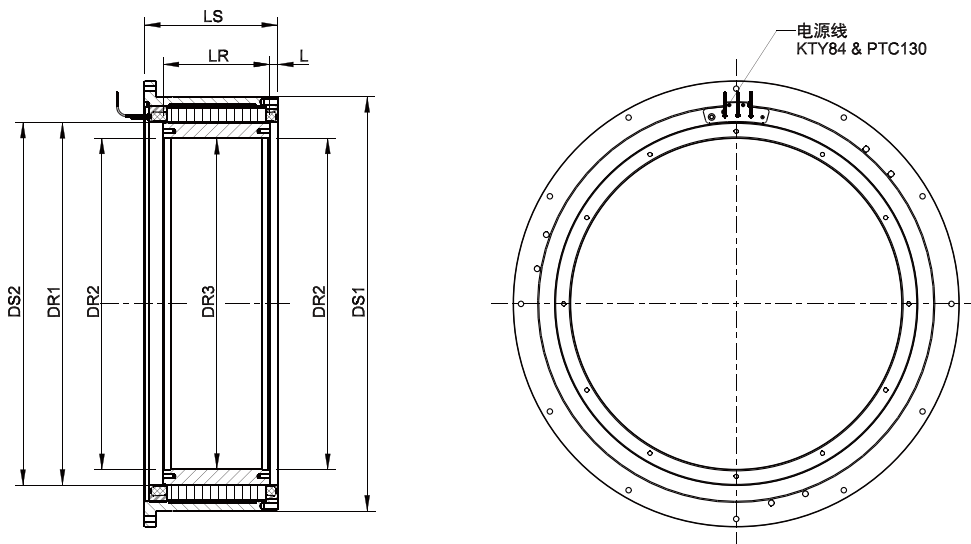

TK1340

性能参数

电机型号 Motor Code	额定转速 Rated Speed	最大速度 Max Speed	额定电流 Rated Current	额定转矩 Rated Torque	额定功率 Rated Power	转矩常数 Torque Constant	最大电流 Max Current	最大转矩 Max Torque
	w_n [rpm]	w_{max} [rpm]	I_n [A]	T_n [Nm]	P_n [kW]	K_t [Nm/A]	I_{max} [A]	T_{max} [Nm]
TK1340-90-202A	2.8	27.7	11.4	2246	0.8	201.64	156	22435
TK1340-250-284C	12	20	110	27500	34.63	284.14	240	49200
TK1340-250-560A	3	11	20.89	10303.09	3.6	528.65	123	41011

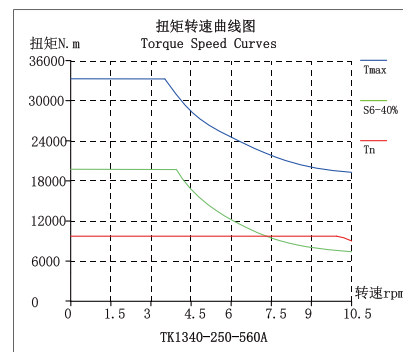
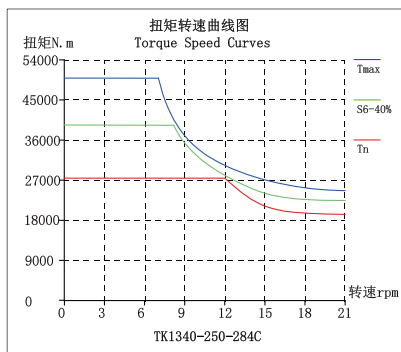
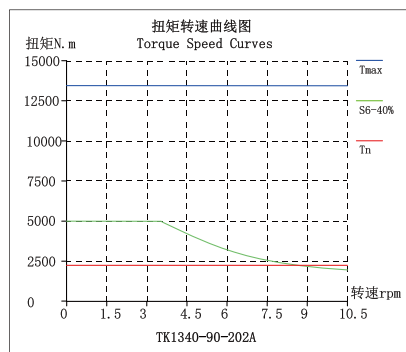

尺寸参数

电机型号 Motor Code	DS1	DS2	DR1	DR2	DR3	LS	LR	L
TK1340-90-202A	1382	1180	1177.2	1100	1101	200.5	130	35.25
TK1340-250-284C	1420	1180	1174.6	1079	1080	441	311	65
TK1340-250-560A	1390	1180	1177.2	1100	1101	370	326	22

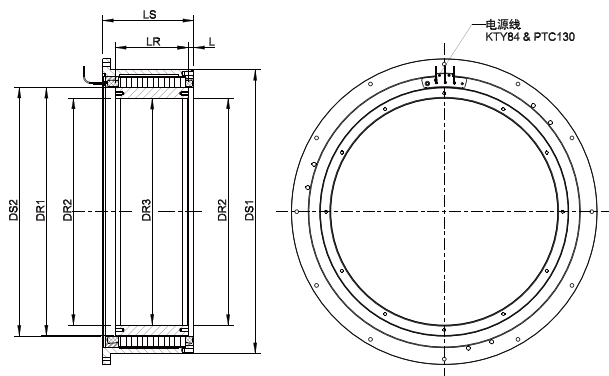

TK1340-90-202A/TK1340-250-560A

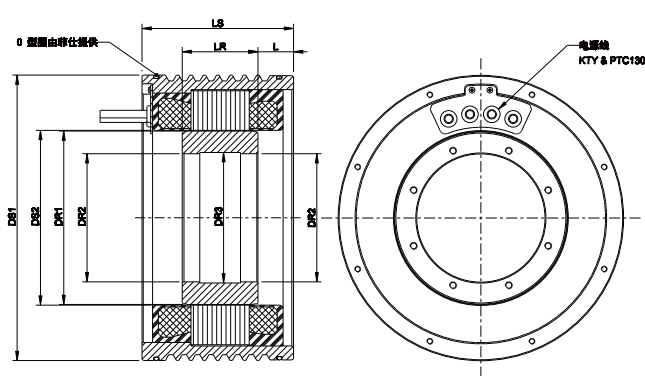

TK1340-250-284C

TK1700

性能参数

电机型号 Motor Code	额定转速 Rated Speed	最大速度 Max Speed	额定电流 Rated Current	额定转矩 Rated Torque	额定功率 Rated Power	转矩常数 Torque Constant	最大电流 Max Current	最大转矩 Max Torque
	ω_n [rpm]	ω_{max} [rpm]	I_n [A]	T_n [Nm]	P_n [kW]	K_t [Nm/A]	I_{max} [A]	T_{max} [Nm]
TK1700-380-865A	4	7	24.08	20379.41	8.89	865.09	145	87115
TK1700-550-68C	90	150	1589	95700	902	68	3259	155900

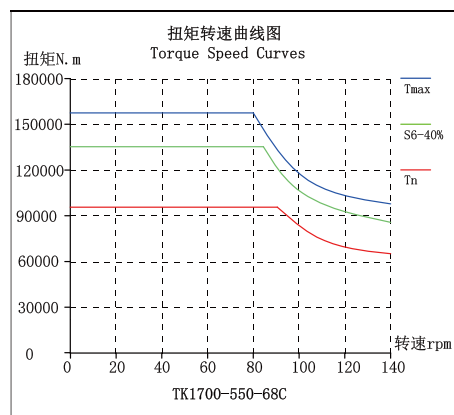
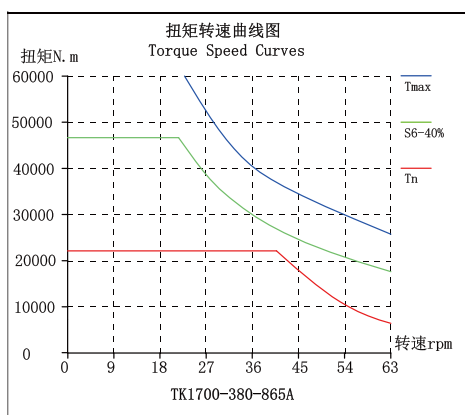

尺寸参数

电机型号 Motor Code	DS1	DS2	DR1	DR2	DR3	LS	LR	L
TK1700-380-865A	1740	1502	1498.2	1432	1436	470	447	11.5
TK1700-550-68C	1770	1502	1496.6	1360	1361	830	617	106.5

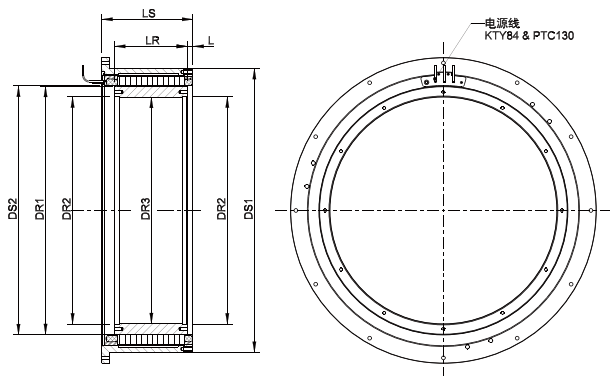

TK1700-380-865A

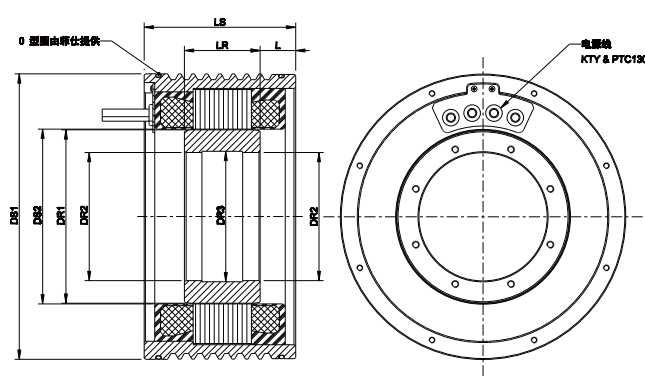

TK1700-550-68C

菲仕总部 PHYSIS HEADQUARTER

宁波菲仕技术股份有限公司

Ningbo Physis Technology Co., Ltd.

浙江省宁波市北仑区小港安居路 308 号

No.308, Xiaogang Anju Road, Beilun District, Ningbo, China

总台热线 /Tel: +0086-(0)574-26922600

国内业务 Domestic Sales

销售热线 /Tel: +0086-(0)574-23459197

邮箱 /E-mail: Sales@physis.com.cn

海外业务 Overseas Sales

销售热线 /Tel: +0086-(0)574-23459168

邮箱 /E-mail: OverseaSales@physis.com.cn

售后服务 After Sales

服务热线 /Tel: +0086-(0)574-23459183

+0086-(0)574-23459182

邮箱 /E-mail: Aftersales@physis.com.cn



扫一扫了解更多

版本编号: PHMTSM2603-V01

由于产品的不断更新和改进,本产品型录中的部分产品数据信息会产生变化,为了能提供更好的服务,建议您在查阅本产品型录的同时,请联系我们,以便您及时获得最新的资讯。

All technical data, drawings and product information contained here may be subject to change, in order to provide you with a continuously improved products, please contact with us for up to date information.

